

April 2011

die flüsternde **bombe**



This issue:

- DIY Tire Rack
- Winter Party Awards
- Habitat For Humanity
- Mini Returns to Pro Rally

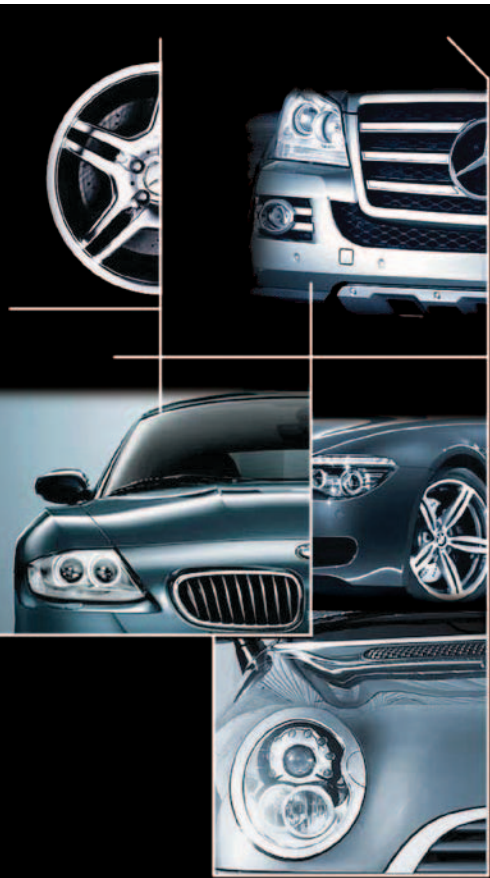

BMW & Mercedes MINI service at its best!

Experience Excellence.

Responsive. Professional. Courteous...
...to you and your car.
Discover why our customers recommend us to their friends.

Your Dealer Alternative.

925.932.8744

2008 Mount Diablo Blvd. Walnut Creek, CA 94596
www.ms-service.com

M SERVICE, INC.
YOUR INDEPENDENT BMW, MINI, MERCEDES, AUDI SPECIALIST



41041 Albrae Street Fremont, CA 94538
Ph: 510-651-8800
Fax: 510-651-1199
Email: info@emcauto.com
Monday-Friday 7:30 AM - 5:30 PM
Saturday 8:00 AM - 2:00 PM

Inspection 1 BMW Service

SPECIALS
starting at
\$250.00

Offer varies per model. Offer expires 03/31/11. Restrictions Apply. Call for details.

Inspection 2 BMW Service

SPECIALS
starting at
\$749.00

Offer varies per model. Offer expires 03/31/11. Restrictions Apply. Call for details.

BMW Brake Service

SPECIALS
starting at
\$249.00

Offer varies per model. Offer expires 03/31/11. Restrictions Apply. Call for details.

COMPLETE AUTO SERVICE AND COLLISION CENTER
100% Lifetime Warranty on Collision Repair



- ✓ BMW Expert Collision Center
- ✓ Factory ASE trained technicians
- ✓ Factory equipment
- ✓ Price Match Guarantee



Uncompromising Quality

EUROPEAN AUTO SPECIALIST

Stop in to see our award winning facility & get a quote on your car & receive a FREE gift.

COMPLETE ECU TUNING & PERFORMANCE CENTER
OPTIMIZE YOUR CAR TO THE FULLEST POTENTIAL

BMW Models	Years	Price Range	HP Gain	Torque Gain	Fuel Economy
E46 3 Series	1998 - 2005	\$545 - \$745	15-20	12-15 ft lb	Up to 20%
E39 5 Series	1995 - 2003	\$545 - \$745	15-20	15-20 ft lb	Up to 20%
E65 7 Series	2002 - 2008	\$645 - \$745	15-25	15-20 ft lb	Up to 20%
E46 M3	2001 - 2006	\$699.00	18-20	20-25 ft lb	Up to 20%
E39 M5	1998 - 2003	\$699.00	25-30	20-25 ft lb	Up to 20%
E9x 3 Series	2005 - Present	\$599.00	15-20	12-15 ft lb	Up to 20%
E6x 5 Series	2003 - 2010	\$599.00	25-30	15-20 ft lb	Up to 20%
E63/4 6 Series	2003 - 2010	\$599.00	25-30	15-20 ft lb	Up to 20%
E90 M3	2008 - Present	\$799.00	20-25	20-25 ft lb	Up to 20%
E60 M5	2005 - 2010	\$899.00	25-30	25-30 ft lb	Up to 20%
E64 M6	2005 - 2010	\$899.00	25-30	25-30 ft lb	Up to 20%
1 Series	2005 - Present	\$599.00	15-20	12-15 ft lb	Up to 20%
135i/35i	2008 - Present	\$799.00	65-80	50-60 ft lb	Up to 20%

WE ARE YOUR BEST ALTERNATIVE TO NEW CAR DEALERS

We will honor and BEAT any valid dealer or independent repair coupon in the Bay Area. Bring in their coupon along with this one & we'll take care of the rest.

Laser Alignment Special

\$89.95
Computerized True Laser
4 Wheel Alignment

FREE! FREE! FREE!

- ✓ Free Towing
- ✓ Free Car Rental on Major Service
- ✓ Free Express Mini Detail on any Work Completed
- ✓ Free 24 point safety inspection

Gift Certificate

up to **\$500 Off**
On Collision Repair
& Insurance Deductible

Restrictions apply. Call for Details.

Best Alternative to Dealership Rates

up to **50% Off**
All Mechanical Repairs

Mechanical Posted Labor Rates. Call for Details

Full Detail Service Special

\$195.95
Regularly priced at \$295.95

Wash exterior by hand, Hand dry, Clay bar, Complete exterior wax, Clean glass, Tire Shine, Leather treatment seats, Trim panels and dash, Machine scrub, 2nd Vacuum, Shampoo carpet & mats,

3M Clear Bra & Window Tint

25% Off

Restrictions apply. Call for Details.

BR RACING

Service, Parts, Inspection, Performance

Everything you need, at the value you desire.



See why we are the FASTEST growing service facility in the south bay
Mention this AD and receive **15% off** your next visit with us!

BR racing (408) 356-1515 brracing@gmail.com
15553 Los Gatos Blvd. Los Gatos, CA 95032

www.brrperformance.com



Contents

The Official Magazine of the Golden Gate Chapter, BMW CCA

FEATURES

- 11 Annual Winter Party & Awards Presentation**
Photos by Jeff Cowan and Kris Linquist
- 12 Habitat For Humanity Volunteer Day**
By Joe Fant
- 14 Mini Readies For The WRC**
BMW Press
- 16 DIY Tire Rack**
By Mark Chambers

DEPARTMENTS

- 5 Across The Board**
- 6 Calendar Of Events**
- 8 Announcements**
- 19 Minutes**
- 23 Toy box**
- 24 New Members**
- 25 BMW CCA Discounts**
- 25 Factory Authorized BMW Dealers**
- 26 Chapter Information**

Your input is encouraged!
Magazine submissions deadline is the first of each month prior to publication.

On the cover

Mini returns to its rally-competition roots and suits up for battle in the 2011 WRC.

BMW Press image

Die Flüsternde Bombe: "The Whispering Bomb"

July 2, 1969-2011 Golden Gate Chapter
Celebrating 42 years of BMW enthusiasm in the Golden Gate region.

www.ggcBMWcca.org

Chapter Email List:

The Golden Gate Chapter has created an email list from the National BMW CCA database to send out event announcements that don't make it into print. We promise to respect your time and limit the frequency of these messages to one or two a month.

This email list is sent to all Golden Gate chapter members who choose to provide an email address to the BMW CCA when they joined or renewed their membership. You have the option to add or remove your address from this list at any time. To add your email address visit <http://lists.ggcBMWcca.org/mailman/listinfo/announce> and follow the directions. To remove your address go to <http://lists.ggcBMWcca.org/mailman/options/announce>, enter your email address and click on the unsubscribe button. There is no password.

Classified Advertising Submissions:

Our online Classified Ads are free to all current BMW CCA members. To submit an ad, please visit Golden Gate chapter's website: www.ggcBMWcca.org. This magazine no longer accepts classified ads for print.

Publishing

Die Flüsternde Bombe is produced monthly (except for combined issues Nov/Dec and Jan/Feb). Article/photo submission deadline is the first day of each month prior to publication. Submissions go to the Assignments Editor at: AE@ggcBMWcca.org.

Commercial Advertising:

This publication is read monthly by over 4,500 BMW enthusiasts in Northern California. Deadline for new ad artwork is the fifth day of each month prior to publication. Please submit artwork to the Advertising Manager.

Commercial advertisers are responsible for supplying their own ad copy. All commercial advertising must be paid in advance. Contact the Advertising Manager for further details: Advertising@ggcBMWcca.org. Please note, this publication is sent Bulk Rate USPS.

For Web or Email-blast advertising rates, please contact the Advertising Manager.

MAGAZINE AD RATES PER MONTH:

Commit to:	1 issue	2-3 issues	4-7 issues	8-10 issues
Inside black and white ads:				
Full page	\$344	\$327	\$310	\$275
1/2 page	\$188	\$179	\$169	\$150
1/4 page	\$135	\$125	\$113	\$105
Bus. card	\$ 88	\$ 84	\$ 79	\$ 70
Inside color ads:				
Full page	\$500	\$475	\$450	\$400
1/2 page	\$263	\$250	\$237	\$210
Specified Placement fee: 25% of ad cost/mo.				
Inside front/back cover (color):				
Full page	\$513	\$488	\$462	\$410
Back Cover:	\$775	\$737	\$698	\$620

The Best in Service & Parts for Your BMW or Mini-Cooper

Northern California's Independent BMW Experts since 1974



- Free Loaner Cars
- Free Shuttle to BART
- Personal Service at Competitive Prices
- We Maintain Your New & Extended Warranties



BMW Specialists Since 1974

(800) 200-4269

email: info@hbspecialists.com

2300 Fourth Street (at Bancroft Way)
Berkeley • (510) 549-1515
Mon-Fri 8:00-5:30 (6:30 Thurs)
Near the University Ave/Hwy 80 exit in Berkeley

Borelli Motor Sports gets car storage.

"I can ask Borelli Motor Sports' on-site mechanic, Scott Riechers to pull out the car and give him a list of things to be prepped, and I know the car will be ready and waiting when I arrive. This way, I get to the track on-time and fresh, rather than exhausted from all the running around before a race."

Mark Magee
Owner, 1995 BMW M3 Lightweight

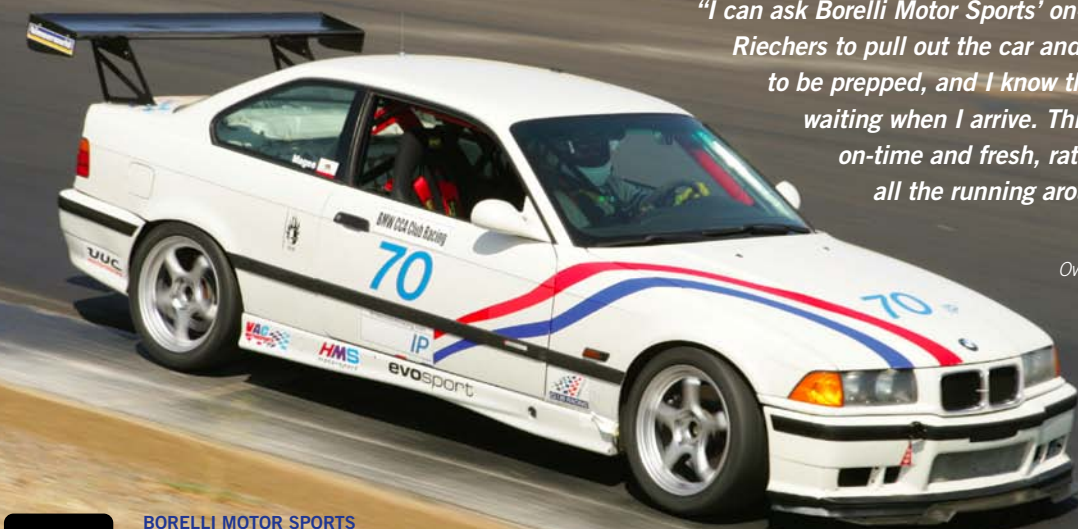

BORELLI MOTOR SPORTS
Premier-class vehicle storage and services at Club Auto Sport
For more information on your service and storage options contact Scott Reichers at Borelli Motorsports
521 Charcot Avenue, Suite 211, San Jose, CA 95131.
408-453-4700 • www.borellimotorsports.com • www.clubautosport.net

Free BMW tech help.

Have a technical question about your BMW or MINI? Our free tech blog – blog.BavAuto.com – has a searchable database containing hundreds of tech Q&As, do-it-yourself articles and videos. Just one more way Bavarian Autosport saves you money.



www.BavAuto.com • 800.535.2002

Check it out at blog.BavAuto.com...



Go Ahead, Be Demanding.

We Are.

At Bavarian Professionals, we take such words as “demanding”, “exacting”, “meticulous” and “prompt” to heart. We are trained experts specializing in BMWs—our clients expect nothing less. After all, some of them are as German in their love for these automobiles as we are. Bavarian Professionals:

Verlangt das beste.*



**Demanding the best.*

510. 524.6000 • 1218 Seventh Street • Berkeley • team@bavpros.com • www.bavpros.com

ACROSS THE BOARD



It's April already; time is moving fast and we are in the driving season again! Well, our driving season doesn't really have definitive time frames: the tours are year-around activities, and car-control clinics are spread across the calendar. However, April means that the 2011 autocross series extravaganza is on the horizon! This season our autocross coordinators have adjusted the car-classification system, so don't be surprised if your car moves to a different class! But there is nothing to worry about—you can always choose a higher class or adjust your car's modifications to get into your desired group.

Speaking of modifications, I hope you didn't miss the extensive report in the March *Roundel* about the newly released Michelin Pilot Super Sport tires. Jeff Cowan, our Pacific Region VP, claims that these max-performance street tires provide feedback similar to R-compound tires. Of course, the way to prove that statement is by trying the new technology yourself: Mount up a set and participate in one of our chapter autocrosses or high-performance-driving schools!

Besides our driving program, the chapter is preparing a lot of activities for those of you who like car shows and historic-car-racing events. We're very excited to be involved with the Palo Alto Concours d'Elegance at Stanford University on June 26. For the first time in the 45-year history of the event, BMW is a featured European marque. Contact Tammi Hull at treasurer@ggcbmwcca.org if you think your car should be part of the display. There's more info about this on the announcements page. In addition, follow our website updates and Facebook page for the info about Club

involvement with the Sonoma Histories Festival at Infineon Raceway in June, and the legendary BMW Festotics—part of the vintage and classic-car week in Monterey—in August. You don't want to miss these very special events!

Modern-day motorsport fans should be pleased to see the tremendous success demonstrated by BMW teams in the various professional racing series. I'm writing this in the afterglow of the BMW success at the Grand-Am Grand Prix of Miami. The Rolex Series and Continental Tire Challenge races were swept by Target Chip Ganassi Racing's Dinan-powered Riley-BMW Daytona Prototypes and Turner Motorsport's M3s. Ganassi's win continued their domination of the Rolex Series; they won nine of twelve races last season—including the final three—and opened the current campaign by topping the podium at the Rolex 24 At Daytona prior to the win at the Grand Prix of Miami. Adding to the BMW legend, Turner Motorsport managed a feat only achieved one other time in Grand-Am history: Bill Auberlen and Paul Dalla Lana drove the #94 BMW to two race wins in one day at Homestead! Personally, I can't wait to witness the return of Grand-Am to Northern California—Laguna Seca will host the races for both race series July 8-9. Let's hope for more victories for BMW teams!



By Aleksey Kadukin, Secretary

This kind of success makes it easy for people to understand why we, as Club members, have a passion for our cars and our automotive activities. When I attend our chapter's events, it's a great pleasure for me to meet up with not only old friends but new members—we're an enthusiastic bunch who share a similar passion. Next time you bump into a board member or one of our event coordinators, share your enthusiasm—please don't be shy! Step right up and talk about your experience. Member feedback is extremely valuable to us and helps us know how to keep you interested in the activities we plan.

Now let's take a look to the calendar... when we will see you next? **GGC**

CORPORATE AUTO WORKS
The preferred choice since 1981

Specialist in
**BMW, Mercedes Benz,
Mini Cooper and Volvo**
Service and Repair

650-691-9477
770 Yuba Drive
Mountain View, CA 94041
www.corporateautoworks.com

BUMPER DOC
Auto Body & Appearance Specialists

Bumper Repair Paintless Dent Repair Auto Body

Phone: 510-567-7284
Toll Free: 1-866-372-8673
Fax: 510-567-7288

14140 Washington Ave.
San Leandro, CA 94578
Hours: Mon-Fri 7:30-5:30
Sat. 9:00-3:00

www.BumperDoc.com

From Generation to Generation

AUTO ANALYSTS II
BMW Specialists Since 1982
SERVICE • PARTS • PERFORMANCE

(510) 582-0201
19592 Center Street
Castro Valley, CA 94546

ANIL SINGH
www.autoanalysts2.com
autoanalysts2@yahoo.com



CALENDAR OF EVENTS

» APRIL

Apr 9 Autocross **GG Chpt**
Marina Municipal Airport, Marina Rodger Ball & Jeff Roberts
www.ggcbmwcca.org autocross@ggcbmwcca.org

Apr 9 Explore the Unknown Tour **GG Chpt**
Santa Rosa Mark Feinberg
www.ggcbmwcca.org NorthAreaRep@ggcbmwcca.org

Apr 16 Board Meeting **GG Chpt**
Mimi's Café, Foster City Donna Seeley
www.ggcbmwcca.org president@ggcbmwcca.org

» MAY

May 1 Western Railway Museum Tour **GG Chpt**
Fairfield & Rio Vista Mike Zampiceni
www.ggcbmwcca.org SocialDirector@ggcbmwcca.org

May 7 Mt. Diablo & Mt. Hamilton Tour **GG Chpt**
Mt. Diablo & Mt. Hamilton Ian Dunn
www.ggcbmwcca.org MembershipChair@ggcbmwcca.org

May 14 Autocross **GG Chpt**
Marina Municipal Airport, Marina Rodger Ball & Jeff Roberts
www.ggcbmwcca.org autocross@ggcbmwcca.org

May 14 Bimmerfest **Bimmerfest**
Rose Bowl, Pasadena
www.bimmerfest.com

May 19 Board Meeting **GG Chpt**
Round Table Pizza, San Mateo Donna Seeley
www.ggcbmwcca.org president@ggcbmwcca.org

May 21 Bay Area Swap & Show **Bay Area 02**
Brisbane Marina, Brisbane Larry Ayers
www.bayarea02.com martiayers@att.net

May 22 North SLO County Tour **GG Chpt**
Santa Margarita Dennis Harrod
www.ggcbmwcca.org SLOAreaRep@ggcbmwcca.org

May 26 Body & Paint Repair Tech Session **GG Chpt**
German Motors Collision Cntr, SF Aleksey Kadukin
www.ggcbmwcca.org TechSessions@ggcbmwcca.org

» JUNE

Jun 4-5 Sonoma Historic Motorsports Festival **Gen. Racing**
Infineon Raceway, Sonoma
http://generalracing.com

Jun 10 Auto Club Speedway Driving School **LA Chpt**
Auto Club Speedway, Fontana Delight Lucas
www.bmwclubla.org djlucas@cox.net

Jun 11 Autocross **GG Chpt**
Great America, Santa Clara Rodger Ball & Jeff Roberts
www.ggcbmwcca.org autocross@ggcbmwcca.org

Jun 11-12 Club Race at Infineon Raceway **GG Chpt**
Infineon Raceway, Sonoma Tamara Hull
www.ggcbmwcca.org treasurer@ggcbmwcca.org

Jun 18 GGC Summer Picnic **GG Chpt**
Private residence, Los Altos Hills Mike Zampiceni
www.ggcbmwcca.org SocialDirector@ggcbmwcca.org

Jun 18 Board Meeting **GG Chpt**
Mimi's Café, Foster City Donna Seeley
www.ggcbmwcca.org president@ggcbmwcca.org

Jun 23 East Bay Meet & Greet **GG Chpt**
Tommy T's Comedy House, Pleasanton Mary Sandkohl
www.ggcbmwcca.org EastAreaRep@ggcbmwcca.org

Jun 25 Meet & Greet/Clear Lake Tour **GG Chpt**
North Bay Area Paula Williamson
www.ggcbmwcca.org NorthAreaRep@ggcbmwcca.org

Jun 26 Palo Alto Concours d'Elegance **P.A. Lions Club**
Stanford University, Palo Alto Tammi Hull
www.ggcbmwcca.org treasurer@ggcbmwcca.org

» JULY

Jul 2-3 Buttonwillow Driving School **Central CA Chpt**
Buttonwillow Raceway, Buttonwillow Peter Kwan
www.cccbmwcca.org

Jul 9 Car Control Clinic **GG Chpt**
Candlestick Park, San Francisco CCC Team
www.ggcbmwcca.org CarControl@ggcbmwcca.org

Jul 10 Autocross **GG Chpt**
Candlestick Park, San Francisco Rodger Ball & Jeff Roberts
www.ggcbmwcca.org autocross@ggcbmwcca.org

Jul 21 Board Meeting **GG Chpt**
Round Table Pizza, San Mateo Donna Seeley
www.ggcbmwcca.org president@ggcbmwcca.org

Jul 23 Poetic Wine Tour **GG Chpt**
Poetic Cellars, Soquel Jeff Cowan & Laura Ness
www.ggcbmwcca.org PacificRVP@bmwcca.org

» AUGUST

Aug 6 New-Owner Tech Session **GG Chpt**
TBA Paula Williamson
www.ggcbmwcca.org NorthAreaRep@ggcbmwcca.org

Aug 17-18 BMW Festorics Wine Tours **BMW CCA**
Carmel/Monterey/Salinas Linda Axelson
www.festorics.org Festorics@bmwcca.org

Aug 19 German Marque Concours **CC Chpt**
Rancho Cañada, Carmel Valley Wayne Wundram
www.LegendsOfTheAutobahn.com BMWWayne@aol.com

Aug 19-21 *BMW Festorics **BMW CCA**
Mazda Raceway Laguna Seca, Salinas Linda Axelson
www.festorics.org Festorics@bmwcca.org

Aug 20 Board Meeting **GG Chpt**
Mimi's Café, Foster City Donna Seeley
www.ggcbmwcca.org president@ggcbmwcca.org

Aug 20 Autocross **GG Chpt**
Marina Municipal Airport, Marina Rodger Ball & Jeff Roberts
www.ggcbmwcca.org autocross@ggcbmwcca.org

» SEPTEMBER

Sep 15 Board Meeting **GG Chpt**
Round Table Pizza, San Mateo Donna Seeley
www.ggcbmwcca.org president@ggcbmwcca.org

Sep 24 Autocross **GG Chpt**
Marina Municipal Airport, Marina Rodger Ball & Jeff Roberts
www.ggcbmwcca.org autocross@ggcbmwcca.org

» OCTOBER

Oct 1 Lost Coast Tour **GG Chpt**
Lost Coast, CA Paula Williamson
www.ggcbmwcca.org NorthAreaRep@ggcbmwcca.org

Oct 10-16 *BMW CCA Oktoberfest **BMW CCA**
Barber Motorsports Park, Birmingham, AL Linda Axelson
www.bmwccaofest.org LindaA@bmwcca.org

Oct 15 Board Meeting **GG Chpt**
Mimi's Café, Foster City Donna Seeley
www.ggcbmwcca.org president@ggcbmwcca.org

Oct 15 Car Control Clinic **GG Chpt**
Marina Municipal Airport, Marina CCC Team
www.ggcbmwcca.org CarControl@ggcbmwcca.org

Oct 16 Autocross **GG Chpt**
Marina Municipal Airport, Marina Rodger Ball & Jeff Roberts
www.ggcbmwcca.org autocross@ggcbmwcca.org

» NOVEMBER

Nov 5-6 Thunderhill Driving School **GG Chpt**
Thunderhill Raceway Park, Willows Kelly Collins
www.ggcbmwcca.org TrackSchools@ggcbmwcca.org

Nov 5-6 Club Race at Thunderhill Raceway **GG Chpt**
Thunderhill Raceway Park, Willows Tamara Hull
www.ggcbmwcca.org treasurer@ggcbmwcca.org

Nov 12 Top Driver Shootout **GG Chpt**
Marina Municipal Airport, Marina Matt Visser & Kris Linquist
www.ggcbmwcca.org autocross@ggcbmwcca.org

Nov 17 Board Meeting **GG Chpt**
Round Table Pizza, San Mateo Donna Seeley
www.ggcbmwcca.org president@ggcbmwcca.org

* Indicates a regional or national Club event

Connect With Us

- GGC Website & Calendar www.ggcbmwcca.org
- GGC-Monthly e-Blast Mailing www.ggcbmwcca.org/?page=subscribe
- Find us on Facebook <http://tinyurl.com/GGC-BMW-CCA-fan>
<http://tinyurl.com/BMWccaFacebook>
- twitter <http://twitter.com/ggcbmwccaautox>
<http://twitter.com/bmwcca>
- LinkedIn <http://tinyurl.com/BMWccaLinkedIn>
- BMW CCA Website www.bmwcca.org
www.bmwccaOfest.org

To add an event to the calendar, email your information to: CommunicationsManager@ggcbmwcca.org

Professional Car Care & Service for Your BMW

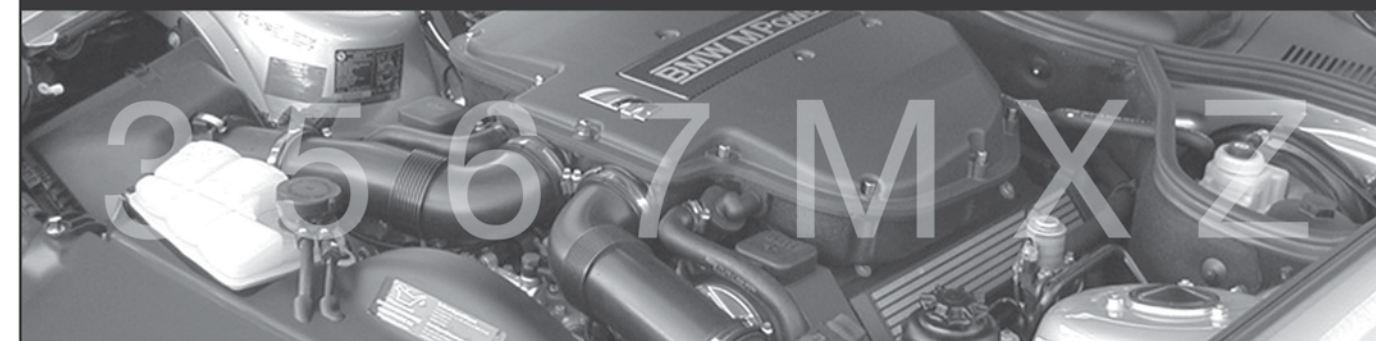

- Maintenance & Repair for All BMW Automobiles
- Shuttle Service to Your Office, Home or BART
- Convenient Location Just Off Highway 80
- Certified and Trained Technicians
- Long-Standing IAIBMWSP Association Member

www.berkeleymotor.com
510 528 1214

BERKELEY MOTOR WORKS
In Tune With Your BMW

736 San Pablo Avenue
Albany, California 94706

**BMWCCA Members
Get 10% Off Labor!**



ANNOUNCEMENTS

APRIL BOARD MEETING

April 16, 11:00 a.m.
Mimi's Café, 2208 Bridgepointe Parkway, Foster City
Round Table Pizza, 1304 W. Hillsdale Blvd., San Mateo
Donna Seeley, president@ggcbmwcca.org

Board meetings are **open to all members**; they're a great way to get involved with your chapter! Come join us for some lively conversation!

Even-numbered-month meetings are on Saturdays at 11:00 a.m. at: Mimi's Café, 2208 Bridgepointe Parkway, Foster City. Odd-numbered-month meetings are during the week at 7:00 p.m. at: Round Table Pizza, 1304 W. Hillsdale Blvd., San Mateo

GGC AUTOCROSS

April 9, 8:00 a.m.
Marina Municipal Airport, Marina
Rodger Ball and Jeff Roberts, autocross@ggcbmwcca.org
www.bmwautocross.com

Autocross events are low- to medium-speed auto-racing events that are often run in parking lots and on airport runways. Generally, a course will be defined using traffic cones. One driver at a time negotiates a course laid out with the cones, or pylons, testing their skill against the clock. Time penalties are charged for disturbing cones, with a penalty of one second per cone. As a rule, each driver takes six to seven runs at an event, and is awarded the best time of all runs taken.

Autocross is an inexpensive, safe way to experience racing. It develops your driving ability, and helps you discover your car's capabilities and limitations—making you a better, safer driver on the road. Many would-be race drivers use it as a jumping-off point into the sport of road racing, but the greatest thrill of autocross is the challenge of beating your own time. It's fun! Want to read more? Check out our Autocross Primer at www.ggcbmwcca under Driving Events Overview, or visit www.bmwautocross.com.

Non-BMWs are allowed to participate, but all participants must be BMW CCA members. If you are not currently a member, you can add a BMW CCA membership during the registration process and pay during checkout.

We no longer accept on-site registration. Event cost is \$45 (a sack lunch is optional for an extra \$5). Our lunch break is only 30 minutes long. You must return on time! The drivers' meeting begins at 9:00 a.m.; if you miss the drivers' meeting you will not be allowed to participate in the event.

2011 Season Dates:

May 14 @ Marina	September 24 @ Marina
June 11 @ Great America	October 16 @ Marina
July 10 @ Candlestick	November 12 @ Marina (Top Driver Shootout)
August 20 @ Marina	

NORTH BAY AREA: EXPLORE THE UNKNOWN

April 9, 9:00 a.m.
Santa Rosa to Winters
Mark Feinberg, NorthAreaRep@ggcbmwcca.org

This driving tour will feature a beautiful day of exploring the back roads between Napa Valley and the Sacramento

Valley, up from Santa Rosa to Winters through Clearlake, and ending back in Santa Rosa.

Come and enjoy roads less traveled! Experience the feel of rural California—while still in the back yard of the Bay Area.

We will meet at 9:00 a.m. at the Starbucks, at 269 Aviation Blvd in Santa Rosa, to sign the waiver and conduct a drivers' meeting. Tour departs at 9:30 a.m..

WESTERN RAILWAY MUSEUM TOUR

May 1, 9:00 a.m.
Western Railway Museum, Suisun
Mike Zampiceni, SocialDirector@ggcbmwcca.org

The Western Railway Museum between Fairfield and Rio Vista is a fascinating place, with lots of vintage trains and associated memorabilia. This time of year is a great time to visit the museum, because it's after the rainy season, but before the summer heat arrives. We welcome the addition of Sacramento Valley Chapter, who will meet us along the route.

Be sure to pack a picnic lunch before you arrive at our initial meeting place—East Bay BMW—at 9:00. After signing waivers and having a brief drivers' meeting, we'll leave promptly at 9:30.

Our route takes us on some great back roads! At around 10:30 we'll meet the Sacramento group in Discovery Bay; from there we'll caravan together up Highway 160 along the Sacramento River, then head west on Highway 12 in Rio Vista to the museum.



Thursday - June 23, 2011 @ 6:00 p.m. \$30/person
Golden Gate Chapter Event: East Bay Meet & Greet

The Wayans Bros.

Join us at Tommy T's in Pleasanton to see the comedy act The Wayans Bros.!

Brothers Shawn and Marlon are famous for their situation-comedy TV series and for a number of movie comedies, such as *Scary Movie*, *White Chick*, and *Little Man*.

We will gather at 6:00 p.m. to mingle and enjoy appetizers provided by GGC BMW CCA. You are responsible for your own drinks and dinner, if you choose. The show starts at 7:30 p.m.. The cost for this sure-to-be hilarious evening is \$30 person.

RSVP by email: EastAreaRep@ggcbmwcca.org with your name, member number, and number attending. **Questions:** Contact Mary Sandkohl, east-area rep (510) 530-4871

Tommy T's, 5104 Hopyard Road, Pleasanton (925) 227-1800
For more info, visit www.tommyts.com.

Upon our arrival, you'll have free time to chat, look at exhibits, or do whatever you'd like. At 12:30 we'll hop aboard a vintage train for a 50-minute interurban ride. When we return, you'll have time to sit in the shaded picnic area and enjoy the picnic lunch you've brought.

Admission is \$10 for adults, \$9 for seniors (over 65), and \$7 for children (ages 2-14).

Please RSVP to social director Mike Zampiceni by Thursday, April 28, and include your phone number in case of last-minute changes.

MT. DIABLO AND MT. HAMILTON TOUR

May 7, 8:00 a.m.-5:00 p.m.
Mount Diablo and Mount Hamilton
Ian Dunn, MembershipChair@ggcbmwcca.org

Join us for a day-long drive as we take on the fun and challenging curves and twists of the roads to Mount Hamilton and Mount Diablo. This tour will take about 8.5 hours, including the various stops along the way. Note: It is likely that we'll have encounters with cyclists, hikers, or even horses, so these roads are not particularly suited to high-speed driving—leave that for the on-track driving schools and the Autobahn!

We'll depart from the Starbucks at 2990 East Capitol Expressway in San Jose. Please bring the printed map and directions (see below) when you meet us at our starting point at 8:00 a.m. The drivers' meeting begins at 8:45, and the tour departs at 9:00 a.m. sharp. Don't be late!

We'll have a late lunch at 2:00 p.m., so plan to pack some snacks.

RSVP to Ian Dunn on or before May 4. The [MtnTour_Directions.pdf](#) can be found on the GGC calendar page listing.

BIMMERFEST 2011

May 14
Rose Bowl, Pasadena
www.bimmerfest.com/bmw-events/

Bimmerfest returns to the Rose Bowl in Pasadena! The event organizers have secured Lot H at the Rose Bowl for 2011, which will allow part of the show to be on the grass.

Event fee: \$20 per BMW to park in the show, \$10 per person to walk in, kids 12 and under are free.

BAY AREA 02 SWAP & SHOW

May 21, 10:00 a.m. - 3:00 p.m.
Brisbane Marina, Brisbane
Larry Ayers, martiayers@att.net, (925)930-9181

The Bay Area Swap & Show is for *Neue Klasse*, two-door, E3, E9, and similar BMWs from the 1960s and 1970s. This year we return to the Brisbane Marina, with cars on the grass. All are welcome at this event, and it's free to the general public who want to show up and walk the show. For those who wish to display their cars, swap parts—or do both—the entrance fee when registering online is just \$25. Onsite registration (May 21 9:00-10:00 a.m.) is \$35. Online registration opens March 8 and closes May 8.

We hope you will come and join in the fun of our eleven-year-old event. Mark your calendar!

NORTH SLO COUNTY TOUR

May 22, 9:30 a.m.
Atascadero
Dennis Harrold, SLOAreaRep@ggcbmwcca.org

Join us for a spirited drive through North San Luis Obispo County as we enjoy the fine trails and scenery east of Atascadero. We'll wind our way through Paso Robles and the vineyard area to the west. Then it's lunch at McPhee's in Templeton, noted for their original (and delicious!) fare. [*I think it's one of the best burgers in California. Mmmm, blood-rare Kobe beef burgers!* —kk]

Meeting time is 9:30 at Tina's Place in Santa Margarita, one mile east of Highway 101 from Exit 211.

BODY & PAINT REPAIR TECH SESSION

May 26, 6:00 p.m.-8:00 p.m.
German Motors Collision Center, San Francisco
Aleksey Kadukin, TechSessions@ggcbmwcca.org

Join us for a tech session covering autobody repairs and paint, at German Motors Collision Center in San Francisco. We will cover several topics, including the latest eco-friendly waterborne automotive finishes (as opposed to solvent-borne coatings), restrictions imposed by the Bay Area Air Quality Management District, body-and-paint repairs to classic and/or collectible vehicles using modern materials, and the importance of wheel alignment—especially after impact trauma.

Please RSVP to Aleksey Kadukin if you plan to attend.

SONOMA HISTORIC MOTORSPORTS FESTIVAL

June 4-5
Infineon Raceway, Sonoma
General Racing, Ltd., www.generalracing.com

Enjoy the show of more than 300 vintage racing cars, spanning every decade of the 20th Century and including pre-war sports and racing cars, sports-racing cars, formula cars, and historic Trans-Am, historic Can-Am, IMSA GTP, FIA GT, and Grand National cars. McLaren is the featured marque in 2011.

AUTO CLUB SPEEDWAY DRIVING SCHOOL

June 10
Auto Club Speedway, Fontana
Delight Lucas and Roger Scilley, DJLucas@cox.net

The LA Chapter's next high-performance-driving school is at Auto Club Speedway—also known as Cal Speedway, and known to real old-timers as Fontana—in the northeast Los Angeles area.

Visit www.bmwclubla.org/calendar.php for more details.

CLUB RACE AT INFINEON RACEWAY

June 11-12
Infineon Raceway, Sonoma
Tamara Hull, treasurer@ggcbmwcca.org

Come enjoy the thrill of watching wheel-to-wheel racing! Come on out and show your support for our BMW CCA Club racers!

GGC SUMMER PICNIC

June 18

Bell Residence, Los Altos Hills

Mike Zampiceni, SocialDirector@ggcbmwcca.org

Please join us for our chapter's annual summer picnic, preceded by an optional driving tour through the Santa Cruz mountains.

- Tour: meets at 9:00 a.m. at Cañada College
- Barbeque Party: starts at 12:00 p.m. in Los Altos Hills

This event is open to all members and is a great introductory event for first-time Club participants. You can choose to participate in the driving tour, the barbeque party, or both. All you need is your car, a full tank of gas, and a swimsuit. The tour will take place on public roads and will be driven at a spirited pace—but please save your racer aspirations for the track.

To participate in the tour, gather at Lot 2 at Cañada College at around 9:00 a.m. to socialize and sign waivers. Everyone, including passengers, must sign waivers, and parents must sign for their children. At 9:45 we'll have a drivers' meeting, and depart promptly at 10:00 to traverse some engaging roads through our mountainous peninsula. We'll arrive at the Bell residence around noon.

Dave and Bonnie Bell have once again graciously invited the chapter to their home for a barbecue and pool party. The feast awaiting us includes ribs, grilled chicken, potato salad, mixed green salad, rolls, and baked beans. After gorging yourself, you can cool off in the pool or relax in the hot tub.

To participate in the barbeque party, you'll need to register online via the calendar listing at our website. Registration will open on or before May 1. The cost per person is \$32. This is always a very popular and well-attended event. Don't miss out!

EAST BAY MEET & GREET

June 23, 6:00 p.m.

Tommy T's Comedy House, Pleasanton

Mary Sandkohl, EastAreaRep@ggcbmwcca.org, (510)530-4871

Join us at Tommy T's Comedy House in Pleasanton for an unforgettable East Bay Meet & Greet. The Wayans Bros.—famous for their situation-comedy TV series and a number of comic movies, such as *Scary Movie*, *White Chicks*, and *Little Man*—are featured for the evening. This should prove to be a night of a thousand laughs!

We'll gather at 6:00 to mingle and enjoy appetizers provided by the chapter. You are responsible for your own drinks and dinner if you choose. The show starts at 7:30.

The cost for this fun evening is \$30 per person. RSVP to Mary Sandkohl with your name, member number, and number of attendees in your party.

NORTH BAY MEET & GREET/ CLEAR LAKE TOUR

June 25

Marin

Paula Williamson, NorthAreaRep@ggcbmwcca.org

You can treat this event as one or two separate activities—a morning coffee in Marin County to hang out and chat with friends, and then a drive up to Clear Lake for lunch by the lake. Join us for one or both! More details coming soon.

BMW FEATURED: PALO ALTO CONCOURS D'ELEGANCE

June 26, 7:00 a.m.–4:30 p.m.

Stanford Campus, at Sand Hill Rd. & Stock Farm Rd.

Tammi Hull, treasurer@ggcbmwcca.org

www.paconcours.com

For the first time in the 45-year history of the Palo Alto Concours d'Elegance, BMW is the featured European marque! This show dates back to 1967, when the Palo Alto Host Lions Club organized and sponsored the first Palo Alto Concours d'Elegance in order to raise money to help local communities. Over the years, the concours has grown into a magnificent event with acres of exquisite cars, and has raised well in excess of \$1,000,000 for approximately 35 local community organizations.

As BMW is the featured marque, your BMW might just be one of the many we'll see on display this year. Show your own BMW, or simply take in the sights of pristine special and collector vehicles, which can span from Pebble Beach winners to new Italian exotica, to Japanese "rice rockets," to collectable military vehicles, to vintage travel trailers restored beyond new.

Bring out those vintage BMWs! GGC is seeking a nice range of the older BMWs: pre-war, 501, 502, 503, 507, Isetta, Glas, 1500, 1600, 1800, 2000, 2002, Bavarias, Threes, Fives, Sixes, Sevens, and of course, any M1—anything manufactured before 1986. BMW race cars of any age are requested for display as well. The official deadline for entering your car with the concours is coming up soon, so contact Tammi Hull before April 1. Letters of acceptance or rejection will be mailed by June 1, 2011. There will also be a separate BMW parking corral for vehicles of any age.

Interested in judging? If you are a member who would like to be a volunteer judge for this event (or you'd like to become an official SCCA Concours judge), contact Tammi Hull.

Baby photos: Please contact Tammi before April 1 if you have a photo of your BMW that would be appropriate for the official concours program.

You don't want miss this event! Information and applications are at www.paconcours.com.

BUTTONWILLOW DRIVING SCHOOL

July 2-3

Buttonwillow Raceway Park, Buttonwillow

Peter Kwan

Find your place in the sun at Central California Chapter's HPDE just northwest of Bakersfield.

Visit www.cccbmwcca.org for more details.

CAR-CONTROL CLINIC

July 9, 8:00 a.m.–5:00 p.m.

Candlestick Park, San Francisco

CCC Team, CarControl@ggcbmwcca.org

Join us at Candlestick Park for our car-control clinic. You will learn the basics of performance-car control by participating in slalom, skidpad, and emergency-avoidance exercises—with instruction. The car-control clinic is a day-long event that consists of three low-speed exercises: a skidpad, a slalom course, and a braking and accident-avoidance

Continued on page 20



VOLUNTEER APPRECIATION AWARDS

Kris Linquist
Matt Visser

Mark Dadgar
Bob Goebel

Terra Conlon
Will Howe

Pat Madigan

The Annual Winter Party & Awards Presentation At Astaria Restaurant



Photos by Jeff Cowan and Kris Linquist



Guest speaker Matt Bell



2010 AUTOCROSS AWARDS

GONZO Class

Eric Lam 1st Place
Dave Dunwoodie 2nd Place
Ryan Yee 3rd Place

AAA Class

Brian Cheung 1st Place
Praneil Prasad 2nd Place
Jason Sams 3rd Place

AA Class

Reid Conti 1st Place
Tristan Littlehale 2nd Place
Dave Sparks 3rd Place

A Class

Michael Do Couto 1st Place
James Keane 2nd Place
Mark Young 3rd Place

B Class

Christian Duvivier 1st Place
Paul Brancato 2nd Place
Tim Uptegrove 3rd Place

C Class

Brock Parsons 1st Place
Art Kaufman 2nd Place
Paul Oeschger 3rd Place



Volunteer Day: Habitat for Humanity®



By Joe Fant

Volunteers:

- Eric Arnerich
- Evan Arnerich
- Michelle Arnerich
- Andrew Chua
- Dan Fant
- Joe Fant
- Brooke Gibson
- Cole Gibson
- Terry Gibson
- Bob Kile
- Jackie Kile
- Viraj Kumar
- Amy Lee
- Kirk Lim
- Cathy Nguyen
- Brock Parson
- Lynn Sestak
- Bob Stetson



Clockwise from right:

Eric Arnerich began his drive from Santa Maria at 5:00 a.m. so he and his two adult kids—Evan and Michelle—could volunteer to help with tasks like painting house trim. Bob Kile takes a break to chat with one of the soon-to-be-homeowners. Bob Kile and Brock Parsons use the miter saw to trim decorative molding. Dan Fant—Joe's son—makes sure this house will be sealed from outside elements by caulking the siding under the roofline.

"Habitat for Humanity is known throughout the world for its unique building model, in which volunteers work alongside the families who will own the completed homes. Habitat for Humanity Silicon Valley has adapted the model to work in the Bay Area's complex urban building environment.

To begin its unique development process, HfHSV asks the surrounding community to provide the donated labor, building materials, and money necessary to complete a Habitat home. The donated labor helps keep overhead costs to a minimum. Together, volunteers, donors, and partner families make this unique building model work." —www.habitatsiliconvalley.org

many building standards. It was also enlightening to learn that Habitat is leading the way in using green building techniques in their house construction.

For me, the most interesting aspect was hearing the personal story of this new homeowner and her family. In her own words, she didn't need a handout from anybody, just a little helping hand. She explained how she had come to be selected as a Habitat homeowner through an extensive selection process; applicants must meet an income guideline, show a history of responsible credit, have a reasonable debt-to-income level, and perform 500 hours of sweat equity to build their own home.

As the Habitat website explains, "Selected partner families learn how to build their homes on the construction site and are ultimately better prepared to take on the many maintenance responsibilities as homeowners. In addition, each partner family must complete a comprehensive training curriculum designed to educate and prepare them for successful home ownership. Along with building a home comes a pride of ownership and a significant impact on the future success for Habitat children."

In these days of tight budgets that threaten redevelopment projects and low- and moderate-income housing projects in our state, our private-support efforts are all the more critical to supporting affordable housing. Basically, these Habitat homes are sold at about the cost of construction—at zero interest, and no money down for a 30-year mortgage term.

At this building site, there are six houses that are under construction together; the estimated completion date is set for this summer. All of the walls and roofing had been recently completed, so our group was divided into teams to work on exterior caulking, painting, and hanging interior doors. Throughout the day, we worked side-by-side with the Habitat leaders, the new homeowners, and other volunteers. We had a lot of fun, met some new friends, and got to help in a worthwhile cause.

After our work day, our Habitat-volunteer coordinator sent this note:

Our team would like to thank you and your team for taking time out of your busy schedules to volunteer with us at Habitat for Humanity Silicon Valley. Our organization's desire to transform families and strengthen our community depends entirely on generous individuals like you who are willing to volunteer their valuable time.

The work you have done at our Morgan Hill site has touched the lives of our families and our community. We hope that you all enjoyed your time at the site and were able to see the impact your help made.

Once again, please extend our gratitude to your team for taking the time to volunteer with our organization. Your dedication has created a lasting impact in our community.

I also send my thanks out to all who volunteered, and we'll see you again sometime soon!

GGC

You Can Make A Difference, Too!

If you're interested in making a difference in your community, please check out your local HfH website and volunteer your time:

- Butte County: www.buttehabitat.org
- Crescent City: www.habitatforhumanitycrescentcity.org
- East Bay: www.habitatEB.org
- El Dorado County: www.edchabitat.com
- Lake County: www.lakehabitat.org
- Sacramento: www.shfh.org
- San Francisco: www.habitatgsf.org
- San Luis Obispo County: www.hfhsloco.org
- Santa Cruz County: www.habitatsc.org
- Santa Maria: www.nsbhabitat.com
- Silicon Valley: www.habitatsiliconvalley.org
- Solano/Napa: www.solanonapahabitat.org
- Sonoma County: www.sonomacountyhabitat.org



The Legend Returns

Mini lines up in the FIA WRC in 2011.

BMW Group Press

Munich, March 1, 2011

The countdown is on to the return of Mini on the international motorsport stage. This season, the new Mini WRC Team will compete at selected rounds in the FIA World Rally Championship (WRC). The aim is to gain valuable experience in order to be perfectly prepared for the complete 2012 World Championship season.

The Mini John Cooper Works WRC has been developed by Prodrive, based on the Mini Countryman. It is equipped with a 1.6-liter turbo engine (derived from the Mini production models) developed by BMW Motorsport for use in series run according to FIA Super2000 regulations, including the World Touring Car Championship. In addition to its works involvement with the Mini John Cooper Works WRC, Prodrive is supplying customer cars to private rally teams.

“The FIA World Rally Championship is the pinnacle of rallying, making it the ideal platform for demonstrating the competitive spirit of our brand,” says Ian Robertson, member of the Board of Management, Sales and Market-



Dani Sordo and Kris Meeke will pilot the two Countrymen for the Mini WRC Team

ing BMW Group. “Experience is a very important factor in motorsport. For that reason, it is essential we learn as much as possible within a very short time, in order to make up ground on our rivals. The new regulations mean that the gap to the top is smaller than it would have been at another time. We want to annoy the opposition as soon as possible.”

The Mini WRC Team will be putting its faith in experienced drivers when it faces up to the challenge of the WRC for the first time in 2011. Kris Meeke (GB) and his co-driver Paul Nagle (Ireland) have proven their ability in impressive style, listing the 2009 Intercontinental Rally Challenge (IRC) title as just one of their achievements. Daniel “Dani” Sordo (Spain), who will compete alongside his new co-driver Carlos del Barrio (Spain) in 2011, has many years of World Championship experience. Twenty-nine podium finishes from 84 starts in the WRC just go to show the former Citroën works driver has what it takes to battle it out at the top.

Rallying is far from new territory for Mini. In the past, success in this popular motorsports discipline has played a crucial role in defining the brand’s image; three victories at the Rally Monte Carlo in the 1960s made the Mini Cooper S a true legend. Mini also

competed in the European Rally Championship, where it notched up countless triumphs.

“Mini can look back on a successful tradition in rallying,” says Dr. Wolfgang Armbrecht, Senior Vice President Brand Management Mini. “Even up to the present day, there is a core group within the Mini community for which Mini and motorsport just belong together. The WRC provides an excellent communications platform for the Mini Countryman, upon which the Mini John Cooper Works WRC is based.”

The Mini WRC Team has now completed thousands of kilometers of exhaustive testing as part of an intensive development program for the Mini John Cooper Works WRC, with further sessions planned ahead of the team’s debut on Rally Italy in early May. The car to be used in the 2011 FIA World Rally Championship will be presented at the official team launch on April 11 at the Mini plant in Oxford.

The Mini Countryman is the youngest Mini model, and also the first to be equipped with an all-wheel-drive system. Therefore this model provided the logical basis for a competitive rally derivative. The flagship Mini Cooper S Countryman is powered by a 1.6-liter, four-cylinder gas engine, supplemented not only by a twin-scroll turbocharger and direct fuel injection, but also fully variable valve management—offering by far the best relationship between engine power and fuel consumption in its class. The engine produces an impressive 184 bhp, and accelerates the Mini Cooper S Countryman from 0 to 100 kph in 7.6 seconds.

As part of the Minimalism concept, a range of fuel- and emission-reducing features are fitted as standard and/or in appropriate combinations, including Brake Energy Regeneration, the Auto Start/Stop function, Shift Point Display, and the need-based operation of ancillary components.



All Mini Cooper S Countryman and Mini Cooper D Countryman are optionally available with permanent Mini ALL4 all-wheel drive, with an electro-hydraulic differential positioned directly on the final drive, varying the distribution from front to rear in an infinite process. Under normal driving conditions, up to 50% of the engine’s power goes to the rear wheels; under extreme conditions, up to 100%, offering a new, high-traction rendition of the agile handling so typical of Mini.

Continued on page 27



WRC rallies in which the Mini WRC Team will be participating are:

- 5-8 May 2011 Rally Italia
- 16-19 June 2011 Rally Greece
- 28-31 July 2011 Rally Finland
- 18-21 August 2011 Rally Germany
- 29 September-2 October 2011 Rally France
- 20-23 October 2011 Rally Spain
- 10-13 November 2011 Rally Great Britain

DIY Tire Rack

When one set of tires just isn't enough

by Mark Chambers
Courtesy Boston Chapter, BMW CCA



Photo 1: The completed tire rack is a sturdy storage solution.

What's a car guy to do? A tire collection seems to expand to fill all available space. First it was a set of mounted snow tires to give my trusty steed the required grip for a New England winter. Okay, they can spend the off-season on the garage floor under the workbench. Then it was a set of mounted high-performance tires to ensure maximum grip at autocross events—but after realizing how miserable the autocross tires were for my daily 90-mile commute, I added a set of mounted all-season tires. Now this was getting out of hand! Where were all of these tires and rims going to live when they weren't in use? There isn't enough floor space in my garage for another pile of tires.

Say, how about hanging them from the walls?

Thus the tire rack plan was hatched. At first I investigated commercially available racks. They all seemed to be either too big or their \$200 to \$300 cost offended my Yankee sensibilities. (Okay, I was born in Ohio, but I have lived here [Boston] for 50 of my 51 years; that has to count for something.) So I decided to build my own rack, using tools and materials available to almost everyone. I don't have a pipe threader or an arc welder, so steel was out. The aluminum

extrusions available at the local home center didn't seem robust enough, so I chose wood and off-the-rack hardware. A little planning, some advice from a contractor friend, and about four hours of work rewarded me with a design that has worked well for the last three years—and only cost about \$50 in parts. The recent addition of a set of race rubber prompted me to build another rack, so I decided to share the design/build process with fellow Club members.

First of all, the safety disclaimer: If you're not comfortable using power tools, then don't. Hire someone for the construction aspects. Are your wall and ceiling structures strong enough to support about 200 pounds? If you don't know, hire someone who does. Having the rack collapse onto your car would be a REALLY BAD THING.

Second, construction in wood is an inexact science. In theory, all structural members are 16" or 24" on center (OC). In reality, they will be further apart or closer together, sometimes markedly so. An electronic stud-finder is very handy. Measure twice, cut once. You must be able to find the approximate center of all of the structural members. If the screws or screw eyes only catch the edge of a stud or rafter, it's a BAD THING that can—and will—lead to a REALLY BAD THING.

Step 1: Find the site

The first step is to figure out where the rack is going to be mounted. You need about 50" of wall space. You also need 26" of space out from the wall. The height above the floor is dictated by convenience; you want to mount the rack as high as possible without requiring the use of a ladder. In my case, I selected a height of 66", high enough for me to walk under but not so high that anything more than a step stool is required for loading and unloading.

Are there any obstructions? If you look at the top right corner of Photo 1, you will see that one of the garage-door track supports blocks direct access to one of the tires. No big deal; I just remove the inboard tire first. Alignment with the wall studs and roof rafters makes construction that much simpler. My garage has the structural members 24" OC, perfect for making two 22½"-wide bays. If your structure is built 16" OC, you will need to use toe and header supports to spread the bays to the desired two-tire width. (See the Side Drawing.)

Step 2: Check for size

Last question: Will your tires fit into the 22½" bays? As built, 235/40-17s fit with several inches of space left over. If your tires are wider than about 275 mm, you will want to use the toe and header supports and enlarge the rack length to spread the bays to the required size. A little planning now will save major headaches later. A pencil-and-paper drawing will work just fine. I used a computer drafting package, as that's what I'm most comfortable with. By the way, a scale drawing is available in AutoCAD DWG or DXF format; just send a request to me via the *Bimmer* editor at the Boston Chapter website (www.boston-bmwcca.org).

Step 3: Buy the materials

You will need the following items:

- 8-foot 2x4s: four pieces if you are using toe and header supports, otherwise three. Get the best ones you can: kiln dried, as straight and as free of knots as possible. Knots in the areas where the screws go is a BAD THING. I have not used the pressure-treated type as I couldn't get any assurance that the chemicals used wouldn't react with tire rubber.
- 3½"x¾" steel L brackets (plated): three pieces. Usually sold in packages of two with the required screws.
- 5/16"x4" screw eyes: six pieces. Get the ones with the wood-screw thread, not the machine-screw thread. Use the closed-eye type as they are stronger.
- 3/16" welded chain, about 6' long. The required length depends on how close to the ceiling or rafters you mount the rack.
- ¼" quick links: six pieces. These look like a single chain link with a nut that spans one side. We'll use these to connect the chain to the screw eyes and turnbuckles.

Design Plans

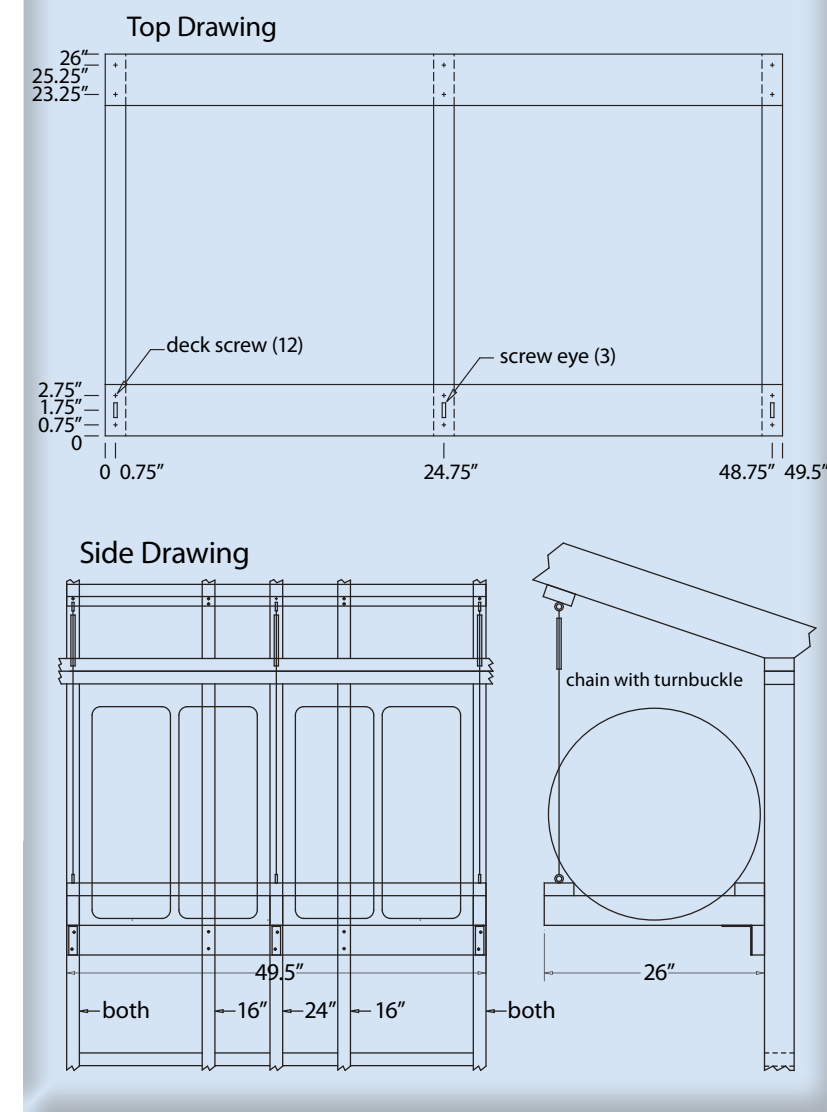

- 5/16" x 9" turnbuckles: three pieces. The ones I used have one closed end and one hook end. If you use ones with two closed ends, you'll need three more quick links.
- #8 3" deck screws (also known as multi-use screws): thirty pieces for the 16" OC design, twelve for the 24" OC design. Get the plated ones for rust resistance. If there is drywall on the chosen wall, you will need six extra screws for the 24" OC design, as the screws that come with the L brackets will not reach far enough into the studs after passing through the drywall.
- Tools required: tape measure, level, square, saw, drill with bits, bolt cutters, and screwdrivers. A plumb bob or piece of string tied to a nut will be very helpful in figuring out where the top screw eyes need to be mounted. Also required is a ladder to reach the top support points.



By *Aleksey Kadukin*
Secretary, GGC BMW CCA

February 19, 2011

Location: Astaria Restaurant, San Mateo

Board members in attendance: Rodger Ball (member at large), Canyon Chan (member at large), Kelly Collins (vice president), Ian Dunn (membership chair), Tammi Hull (treasurer), Aleksey Kadukin (secretary), Donna Seeley (president)

Board members not in attendance: none

Other members in attendance: Jeff Cowan (Pacific Region VP), Ken Glidewell (Peninsula area representative), Mike Zampiceni (Social Events coordinator), Bill Arnold, Derek Arnold, Kris Linqvist

4:22 p.m. meeting called to order by Seeley

Driving-events report (Hull):

- Autocross program is doing well.

- CCC program is doing well, too. Ball shares the intelligence report about Alameda County Sheriff organizing their own CCC at their training course in Pleasanton. Ball proposes to do some recon regarding the possibility of using their facility for our CCC events.

- HPDS: The school at Laguna Seca on March 14 is coming very soon. We might do another school at the same location depending on the success of the upcoming event and instructor availability. Laguna Seca is interested in our renting the track for another school. They've softened the rules a lot: We could do five sessions, allowing up to thirty cars on the track. We're thinking about third school at Laguna Seca at September time frame.

- Club Racing organizers made a major change of the rules for 2011: The program is not limited to BMW cars anymore—any race car can compete.

- Instructor training school (ITS) is set for Fourth of July weekend at Buttonwillow, which potential students consider to be a ridiculous decision.

Communications report (Collins):

- Website support still a challenge: nobody has fixed the technology yet, and there is no established ownership.

- Collins delivers chapter business cards to those who ordered them.

- Percy Chow reports that the *Bombe* is getting a few new advertisers for 2011, making up for some of the advertisers who decided to leave in 2010.

Social-events report (Zampiceni):

- More tours announced on website.

- Summer BBQ party is set for June 18 at Castle Bell.

- Cowan is organizing another winery tour.

- Zampiceni is working with the Porsche Club of America on a joint tour.

Secretary report (Kadukin):

- Most of the 2011 chapter forms have been sent to National; comps form still in progress. (Sent by the time of minutes going to press.)

Tech-session report (Kadukin):

- Kadukin contacted BRRacing for a possible tech session after they expressed a lot of interest in hosting a session. He is working on details.

- Kadukin contacted Big O Tires for another tech session possibility—no details yet.

Membership-chair report (Dunn):

- We have members!

- Dunn ordered postcards for sending to lapsed members and is working on the distribution strategy.

- Dunn shares a statistic from his phone calls to new members: Most people are interesting in HPDS.

Vice-president report (Collins):

- None.

Treasurer report (Hull):

- We have money.

- We have receivables.

President report (Seeley):

- Nothing new.

- Pacific region chapters' monthly conference-call update: Collins participated in the recent one; she says it was starving experience—nothing significant came out from the call.

New business:

- Kadukin is working on chapter truck-and-trailer refinishing project.

Meeting adjourned at 5:18 p.m.



Photo 2: Securing the chain mounts and tires

Step 4: Time to build

Let's build this thing:

Refer to the Top Drawing and Photo 2.

- Cut four pieces of 2x4 to a length of 49½". (Two pieces if you are not using the toe and header supports.)
- Cut three pieces of 2x4 to a length of 26". These are the rack supports.
- Drill six tight-clearance holes in each of two of the long pieces where the deck screws will pass through them. These are now the tire supports.
- Assemble the tire supports to the rack supports using the deck screws. Make sure the assembly is square before installing the screws.
- Drill three pilot holes (whatever size your screw eyes require) and install the screw eyes in the front tire support. Drive the screw eyes in as far as you can so that the threads engage the tire supports and the rack supports.

- Mount the toe support (if you are using it) to the wall studs using tight-clearance holes in the support and deck screws. Make sure the support is level before installing the screws. Use the L-bracket mounting holes as a drill guide. Do not install the center bracket at this time. If you are not using the toe support, you can simply mount the two end L brackets to the wall studs using the appropriate screws.
- Place the rack assembly on the L brackets/toe support and support the outside edge with a helper or suitable piece of lumber. Make sure the brackets are centered on the rack supports before installing the screws. Install the center L bracket at this time. (See Photo 3.)
- Using the plumb bob, find and mark the points on the ceiling or rafters where the top screw eyes will mount. Center these points over the lower screw eyes. If you are using the header support, install it centered over these points using tight-clearance holes in the support and deck screws. Drill pilot holes for the screw eyes and install them. (See Photo 4.)
- Loosen the turnbuckles about ¼" and connect them to the top screw eyes. Install a quick link in the lower eye of each turnbuckle. (See Photo 4.)
- Install a quick link in each of the lower screw eyes.
- Connect the chain to a top quick link and mark the chain link that matches up with the lower quick link. Using the bolt cutters, cut the chain link below the marked link. Cut two more pieces of chain the same length and install them in the upper quick links. Tighten the quick-link nuts.
- Gently lift the front edge of the rack just enough to allow the lower end of the chains to be installed in the lower quick links. You could also loosen the turnbuckles until the chain slips easily into the quick links. Tighten the lower quick link nuts and adjust the turnbuckles so that the chains are under tension and the rack is level.
- Remove the support from the front edge of the rack and then stand back and admire your new tire rack.

Continued on page 18



Photo 3: Close-up of the mounting brackets

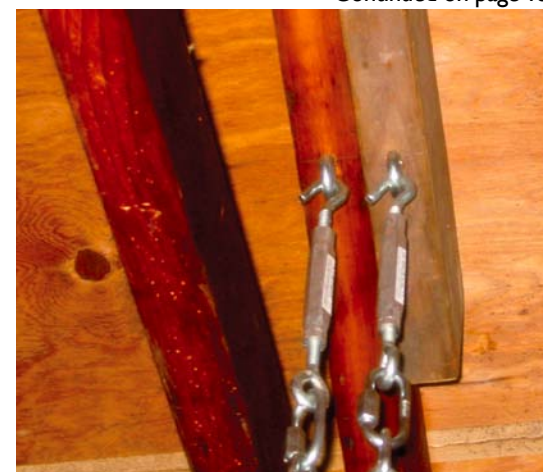

Photo 4: Ceiling assembly

simulation. These exercises will better prepare you for situations on the track, as well as in everyday driving.

NOTE: This car-control clinic is a pre-requisite for all first-timers (with no previous on-track driving experience) who plan to attend our high-performance driving schools.

Event cost is \$110 for BMW CCA members and \$158 for non-members (which includes a one-year BMW CCA membership). Lunch is included. If you plan to attend, please read our event overview!

Registration will open about six weeks prior.

SOUTH BAY AREA: POETIC WINE TOUR

July 23

Poetic Cellars, Soquel

Jeff Cowan and Laura Ness, PacificRVP@bmwcca.org

Feeling lyrical? Find your rhythm with a spirited drive through the Santa Cruz Mountains that includes a stop for a catered lunch buffet, vineyard tour, and wine-tasting at Poetic Cellars Winery in Soquel.

Poetic Cellars is located on 36 pastoral acres in the majestic Santa Cruz Mountains. One of the newest wineries in the area, it is set amid the rolling, oak-studded hills and the solitude of a country estate. This is the perfect place to relax and enjoy fine wine in an unhurried, tranquil atmosphere. Winemaker Katy Lovell is dedicated to creating poetry in the bottle, from the finest sources she can farm and find.

Arriving at the winery, we will take a short tour of the vineyards, and then sample wines paired specifically for our catered lunch buffet.

The price is \$23 per person, which includes the tasting fee and the lunch buffet of hummus with pita and vegetables, grilled sausages, Summer Fiesta potato salad, and Asian chicken salad.

Watch the website for additional tour and wine-tasting details, and for the opening of registration.

TECH SESSION FOR NEW OWNERS

August 6

TBD

Paula Williamson, NorthAreaRep@ggcbmwcca.org

This tech session will cover topics for new owners. More details are coming soon.

BMW CCA FESTORICS LONG WEEKEND 2011

August 17-21

Monterey area

Linda Axelson, Festorics@bmwcca.org

www.festorics.org

WINE TOURS: AUGUST 17-18

August 17: Carmel Valley/Monterey wine-tasting tour

Ag Venture Tours will be offering a full-day wine tasting tour, featuring motorcoach accommodations to three excellent wineries in the beautiful Carmel Valley and Monterey areas. The tour will start with a visit to Château Julien Wine Estate for a private tour, walk, and wine-tasting. We will then visit the tasting rooms of Ventana Vineyards and Heller Estate to taste their premium wines. Lunch will

be at Tarpy's Roadhouse Restaurant. As we drive through the area, your expert guide will discuss the Monterey County wine industry; we will observe beautiful scenery and discuss local points of interest.

August 18: Salinas Valley wine-tasting tour

This full-day wine-tasting motorcoach tour of the Salinas Valley includes a visit to Manzoni Farms/Vineyards for a tour and taste of their premium wines. We will then visit Hahn Estates/Smith & Hook Winery for a delicious barbecue picnic lunch and wine-tasting. The tour will finish at Paraiso Vineyards for a private tour and wine-tasting. Along the way, we will see the world-famous Salinas Valley, "Salad Bowl of the World," and learn about the local agricultural industry, which supplies many of the fresh vegetables consumed throughout the United States.

It's an affair you won't want to miss! Additional information can be found at www.festorics.org.

BANQUET AND VINTAGE RACES: AUGUST 19-21

August 19-21: BMW CCA Festorics meets Rolex Monterey Motorsports Reunion

Also sponsored by Liberty Mutual Insurance, Sonax, and the BMW CCA, the annual BMW Festorics at the Monterey historic races—now called the Rolex Monterey Motorsports Reunion—celebrates the mystique of BMW and our appreciation for the marque. Set for August 19-21, the Festorics features a two-day parking corral with hospitality tents overlooking Laguna Seca's Turn Five. The Festorics package includes the opportunity to buy corral tickets, lunch tickets, a special BMW banquet ticket, and event tickets to the Reunion races themselves—all from one convenient source!

But the corral at the track is only one attraction. Don't miss the BMW CCA banquet at the Rancho Cañada Country Club in Carmel Valley.

CENTRAL CAL CHAPTER'S GERMAN-MARQUE CONCOURS

August 19

Rancho Cañada, Carmel Valley

Wayne Wundram, BMWWayne@aol.com

www.LegendsOfTheAutobahn.org

Sponsored by Liberty Mutual Insurance, Sonax, and BMW CCA, the BMW CCA West Coast Summer Concours will again host beautiful BMWs of all ages, as well as entrants from the Porsche and Mercedes-Benz clubs who will share this event. The concours will be held on Friday, August 19, at the Rancho Cañada Golf Course, located on Carmel Valley road just east of California Highway 1. With separate club concours judging sites and club corral parking areas, the concours will again kick off the BMW CCA Festorics weekend.

This event will be limited to marque-club members only. Space will be limited to 200 BMWs, 100 Porsches, and 50 Mercedes-Benzes, and will include a parking corral area for those registered but not participating in the judging activity. It is also a perfect location for a picnic lunch. Food and beverages will also be available on-site. Additional attractions may include guest speakers and specialty vendors.

Online registrations for this event are now open at www.MotorsportsReg.com. You may register your car

and pre-order lunches and event T-shirts. For additional information, please visit www.legendsoftheautobahn.org.

BMW CCA OKTOBERFEST 2011

October 10-16

Barber Motorsports Park, Birmingham, AL

Linda Axelson, LindaA@bmwcca.org

www.bmwccaOfest.org

So much to do, so little time! There are five days of driving school to choose from, a TSD rally, car-control clinic, Club Racing school, fun rally, concours, etc.

Registration is open! Book your hotel reservations now!

NORTH BAY AREA: THE LOST COAST TOUR

October 15

Paula Williamson, NorthAreaRep@ggcbmwcca.org

Have you heard of California's Lost Coast—or been there? This will be the pinnacle driving event of the North Bay region for 2011! Plan on arriving Friday night, then enjoying the terrain of the Lost Coast with us on Saturday—and finish the day with the group for dinner.

More details to follow on this amazing tour!

THUNDERHILL DRIVING SCHOOL

November 5-6

Thunderhill Raceway Park, Willows

Kelly Collins, TrackSchools@ggcbmwcca.org

Come learn the art of high-performance driving at our Thunderhill driving school! It's a great place for both first-timers and experienced drivers alike.

The focus of our driving school is on safety and education; every student is assigned an instructor until they are signed off at the event. Our dedicated team of experienced instructors will help you learn at a comfortable and enjoyable pace.

Your vehicle must undergo a technical inspection by a qualified mechanic within 30 days of the event. Bring the completed, stamped, and signed GGC Tech Inspection Form with you to registration. Self-techs are not allowed. Tech-inspection forms other than GGC will not be accepted.

Watch the website for registration info and more details, coming soon.

CLUB RACE AT THUNDERHILL RACEWAY

November 5-6

Thunderhill Raceway Park, Willows

Tamara Hull, treasurer@ggcbmwcca.org

Come enjoy the thrill of watching Club racers compete in wheel-to-wheel racing with their BMWs!

This event will be combined with our driving school, so you can show your support for our Club racers when not on track yourself.

GGC



DIABLO MOTORS

AUTO SALES, BROKERAGE & SERVICE

The ONLY Dealership with Service So Personal
It's Certified. *It's Diamond Certified!*



CALL (925)830-4BMW(4269)

3211-C FOSTORIA WAY - SAN RAMON, CALIFORNIA 94583

All Current BMW CCA Members
SAVE 10% OFF Repairs & Parts

WHAT MAKES US SO SPECIAL?

- BMW CCA Members for over 20 years
- Cars are sold with a 90-day bumper-to-bumper warranty for your peace of mind.
- We sell our cars at wholesale to the public
- We offer a true broker service. Tell us exactly what you want and we'll get it for you for no extra charge.
- Each BMW receives a 200-point inspection by a BMW factory-trained technician to ensure quality, reliability and safety.
- We also offer prepaid maintenance plans, extended warranties, financing, and trade-ins too.
- We're EXTRA Non-Dealer-ish.

The ONLY Dealer in
the ENTIRE EAST BAY!



Visit Us Online Now and Check-out Our Inventory at www.diablotmotors.com



A Better BMW Service Experience

NOT JUST FOR RACECARS,
Trackstar Racing offers personalized care
for every Ultimate Driving Machine.

The difference?

Individual attention and clear
communication from a BMW factory
trained Master Technician. With
competitive rates and 33 years of
experience, your satisfaction is
guaranteed.

Steve Casaletto
650.961.2350

TRACKSTAR
RACING
www.trackstarracing.com

2139-D OLD MIDDLEFIELD WAY MOUNTAIN VIEW CA 94043

Bill Arnold
415 459 BMWWS
(2697)

Bill Arnold Independent BMW Service

68-D Woodland Avenue
San Rafael, CA 94901

925.947.6848
1275 Parkside Drive • Walnut Creek, CA 94596

WOLFGANG'S
foreign car service

NEW WEBSITE
WWW.BAVARIANMOTORSPORT.NET

BMW CAR SERVICE & REPAIR
Comprehensive Repairs
Advanced Computer Diagnostics
Automatic Transmission Service
Inspection I & II Service
Brake & Suspension Service
Preventative Maintenance

BMW TRACK CAR CARE
Performance Engine Modifications
Track School Inspection & Preparation
Brake & Suspension Upgrades

Bavarian Motorsport, Inc.
Quality is a journey of passion

408.956.1662 247 Houret Drive, Milpitas, CA 95035

CONNECT WITH US
facebook <http://facebook.com/BavarianMotorsport>
twitter http://twitter.com/B_Motorsport

Cool Carbon™ Performance
Brake Pads

Entwickelt Für FAHREN OHNE GESCHWINDIGKEITSBEGRENZUNG

BMW - MINI - PORSCHE
Special Spring Pricing for
Golden Gate Chapter
Members at
AutoIndividual.com
coupon code "ggc2011"
www.coolcarbonperformance.com

KENWOOD KCA-BT300: BLUETOOTH® ADAPTER

Now that California has a law that makes it illegal to drive and use a mobile phone hands-on—to talk, text, read, etc.—what are the hands-free alternatives out there?

In the past couple of years, I've gone through three Bluetooth headsets. The first was the cheapest Motorola unit I could find; it barely hung on my ear and, once the car was in motion, it was barely loud enough to hear. The second unit was from Plantronics—better design, but it just didn't fit right. I finally splurged on the (ugly!) Jawbone unit. It sounded great, and had military-grade technology for noise cancelling, but in the end, it still liked to fall off my ear.

Around the time I gave up on Bluetooth headsets, I purchased a new Kenwood stereo for my BMW—one that would play my iPod through a USB port. It was about a year before I finally noticed that the stereo also had the capability to work with the Kenwood KCA-BT300 Bluetooth hands-free cell-phone unit! This unit has been in production for about five years now. It's had minimal changes over that time—mostly firmware upgrades.

So I decided to give myself a birthday present. After searching the Internet and finding prices ranging from \$123 to \$160, I found a refurbished unit on eBay for \$85—a price definitely comparable to yet another headset.

The unit is fairly simple and features:

- A compact 4.75"-by-1.25"-by-4.75" gray case with a hardwired power cord that plugs into the back of your stereo.
- A microphone cord with a 3.5-mm mini jack: this plugs into the unit, and into a microphone on a swivel base, which is installed where you want to speak into it.
- Two optional pass-through ports for Kenwood components that have a 5L or KAB connector.
- A set of dip switches to be set to match the receiver it's connected to.
- It's caller-ID enabled, can be paired with up to five Bluetooth phones, and will download each phone's address book. The keys or touchscreen of your compatible Kenwood head unit can be used to dial a number, answer an in-coming call, or end a call.

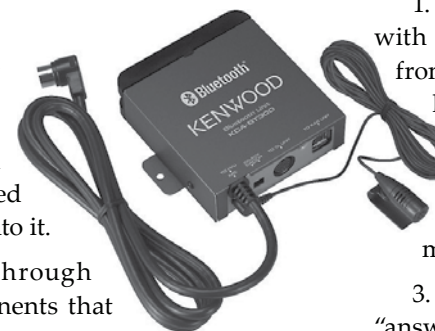

Installation is fairly simple, but it does take some planning. First you have to find some space for the module; I choose to mount it under my glove box in the foot well, securing it with 3M double-stick tape and two small self-tapping screws.

Next comes, fishing the power and mic lines to where they need to go. I pulled my car's OBC and accessory box out from the dash—it comes out with a gentle tug—in order to run the power cord behind the climate-control unit to the stereo head unit. I ran a similar path with the mic cord, but snaked it under the steering column and up to the gauge cluster.

With the lines are in place, I pulled the receiver deck out and plugged in the power cord and mic cord.

A daunting project? No—it's barely an hour of work, and the only special tool is the stereo-removal tool that comes with most stereo decks, and maybe a small screwdriver for the self-taping screws for the module.

Once I powered on the Kenwood stereo deck, it automatically sensed the Bluetooth module and displayed an "ON" message. (The message will vary from model to model of stereo deck.) Currently, I have the module synced with my iPhone 4. Pairing was pretty painless: Set the iPhone to look for Bluetooth devices, then confirm when it finds the stereo.



By Percy Chow

But what's the big benefit, other than being able to talk hands-free?

1. No more power issues; unlike a Bluetooth headset with its battery-life problems, the module draws power from the stereo—that is, from the car. As long as your head unit is on, you can talk hands-free until you're blue in the face.
2. It plays through your car's speakers. Plus, when a call comes in or out, the unit automatically mutes the music.
3. It's truly hands-free: when a call comes in, just hit "answer" on your phone and the call is automatically routed to the Bluetooth module—no more fumbling with switches or knobs to make it work. Also, remember that my phone is safely secured within easy reach on my windshield by the HaiCom iPhone holder (see Toy Box in the June 2010 *Bombe*).

Again, keep in mind that you still have to turn your stereo on when you start the car, and have the phone's Bluetooth on for the pairing to happen. And Bluetooth can be... well... finicky. Sometimes Bluetooth likes to drop a connection if it isn't being used or doesn't properly pair up. But I've only noticed this in about one out of fifty times. The solution? Turn off the stereo or phone—or both—turn them on again, and allow them to re-sync.

That's all it takes to be a law-abiding citizen! **GGC**

Welcome!

NEW MEMBERS

Last	First	City	Model	Year	Referred By	Last	First	City	Model	Year	Referred By
Baker	Benjamin	San Francisco	135i	2009		Mills	Lisa	San Francisco			
Barry	William	Sunnyvale	M3	2003		Mohamed	Marleen	San Jose			
Beal	Steve	San Anselmo	Dinan 540	2002		Nadell	Michael	Scotts Valley	Cooper S	2007	
Beverly	Robert	Carmel	M3	2004		Nielson	Thomas	San Anselmo	335d	2011	Gordon White
Chan	Annie	Foster City	528i	2009		O'Connor	Matthew	San Ramon			
Coffey	David	Larkspur	330Cic	2002		Orjuela	Camilo	San Jose	Porsche 911	2000	
Cohn	Marc	Albany	Volvo 850 Turbo	1995		Pester	Bob	Lafayette	X5	2010	Michael Heller
Damico	Adam	Richmond	325ix	1988		Peterson	Gregg	Santa Cruz	E30	1988	
Deol	Vikrum	Pleasanton	M3 (E90)	2009	Scott Nierotka	Pond	Tavis	Windsor	530i	2001	
Faust	Jeff	San Jose				Rahman	Jami	Dublin			
Figone	Lou	San Jose	540IT	1999		Rambaldo	Richard	San Francisco			
Flower	Jeff	San Francisco			Andy Nilon	Rambaldo	Tara	San Francisco			
Forsythe	Jason	Pleasanton				Richards	Steven	Brisbane			
Forsythe	Ryan	Pleasanton				Robinson	Thomas	San Francisco			
Fountain	Chris	Santa Clara	325is	1993		Roell	Charles	San Francisco			
Garnish	Laura	Mill Valley	Dinan Z3	2001		Schoknecht	Kim	San Mateo			
Hansen	Brian	Santa Cruz				Sreekanti	Vibhav	Pleasanton	328i	2007	
Harrison	Joseph	Mountain View	Mini Mk1	1962		Stilling	Tony	San Francisco	330xi	2003	
Hays	Kyle	Saratoga				Swider	David	San Rafael	330i (E46/4)	2006	
Hiles	John	Lafayette	328Ci	2000		Tempesta	Marc	San Rafael	335i (E90)	2007	
Hill	Ralph	Los Gatos				Thompson	Stephen	Paso Robles	335i (E92)	2008	
Huang	Benjamin	San Francisco	M3	1997		Tse	Alex	Danville	550i	2011	
Hutt	Robert	Petaluma	535i GT	2010		Vasil	Christopher	Los Gatos			
Karkouti	Omid	Los Altos	330Ci	2001		Vasquez	Rose	Los Gatos			
Kilcline	John	Palo Alto				Walker	William	Los Gatos	Z3	1996	
Lo	Alvin	El Sobrante	M3	2011		West	Patricia	Berkeley	328i	1996	
Marseille	Jesse	Oakland				Yamamoto	Yosuke	San Francisco			
Martinez	Gabriel	Oakland				Zhao	Mason	San Diego	335i (E90)	2008	

Curious about the E codes? www.bmwarchiv.de/e-code



Your North Bay BMW & Mini Dealership Alternative

- A one stop shop for scheduled maintenance & performance upgrades
- Factory trained technicians using the latest diagnostic equipment
- 10 bay facility with night drop & shuttle service
- BMW CCA members receive 10% off parts and labor

**515 Tuolumne Street
Vallejo, California 94590**
(Right off Highway 80/Solano Exit)

Call (707) 643-7548

www.MServiceGarage.com

IMPORT CONNECTION

Servicing BMW's in Campbell since 1990



BMW Scheduled Inspections and Service Preventive Maintenance, Repairs and Upgrades for:

- ✓ Engine
- ✓ Transmission and Driveline
- ✓ Suspension
- ✓ Brakes

408-379-7828

25 S. Central Ave in Campbell, California

We are passionate about BMW's and it shows in our work

BMW CCA DISCOUNTS

One of the many member benefits of BMW CCA is a members-only discount at various participating services and dealers. Below you can find the businesses in our area who offer our members a discount. Please note that businesses often require you to show your current CCA membership card in order to receive the discount.

Please contact us with any deletions to the list due to a company being out of business. We ask that additions, changes, or deletions (no longer participating in discount program) are requested by the business owner directly. Updates should be directed to: CommMgr@ggcbmwcca.org.

Independent Service & Supply Discounts		
2002 Haus	San Luis Obispo	805 541-2002 5% Parts
Alekshop	Pleasanton	925 609-4559 10% Labor/Free Tech Insp
Auto Analysts	Castro Valley	510 582-0201 10% Labor
Auto Concierge	Fremont	925 852-1962 10% off quoted full detail
Bavarian Enterprises	Sunnyvale	408 737-6100 Various Parts
Bavarian Motorsport	Milpitas	408 956-1662 10% Parts
Bavarian Professionals	Berkeley	510 524-6000 10% Labor
Bavarian Tuning	Santa Rosa	707 575-3757 10% Parts/Labor
Berkeley Motor Works	Albany	510 528-1214 10% Labor
Bimmers BMW Service	San Carlos	650 591-2474 Various
BMW Performance Driving School	Spartanburg, SC	BMWusa.com 15% off driving programs
BTM Motorwerks	Campbell	408 369-1911 5% Parts/Labor
Catalpa Street Garage	Santa Cruz	831 464-2269 10% Parts
Classic Euro-Asian	Oroville	530 534-6887 10% Parts
Conversion Techniques	Oakland	510 639-0911 Various
Diablo Motors	San Ramon	925 830-4269 10% Parts/Labor
Dinan Engineering	Mountain View	650 962-9401 10% Labor
Dinan Engineering	Morgan Hill	408 779-8584 10% Labor
Double 02 Salvage	Hayward	510 782-2002 10% Used Parts
Edge Motorworks	Dublin	925 479-0797 10% Labor
evosport	www.evosport.com	888 520-9971 10% Parts, \$1000svc=free dyno
Extreme Performance	San Jose	408 923-6404 10% Parts/Labor
German Auto	Santa Maria	805 922-1262 10% Parts
GS Tuning	Santa Rosa	707 284-2680 10% Sales/Service
Heyneman European	San Rafael	415 499-1234 \$50 off Service
Jam Engineering	Monterey	831 372-1787 Various Parts
John Gardiner Automotive	San Francisco	415 777-2697 10% Labor
Nate Smith's Optimal Auto	Santa Cruz	831 476-1332 10% Parts
M Service	Walnut Creek	925 932-8744 10% Parts/Labor
Milt's Service Garage	Vallejo	707 643-7548 10% Parts/Labor
Patelco Credit Union	www.Patelco.org	415 442-6200 Special Offer
Phaedrus	San Francisco	415 567-8000 10% Parts
Performance Art	Gilroy	408 848-6325 10% Service/Labor
Performance Technic, Inc.	Pleasanton	925 426-1361 10-15% Parts
Portola Valley Garage	Portola Valley	650 851-7442 10% Labor
RennWerks	Campbell	408 370-7480 15% Labor
Rossi's Tire & Auto Service	Salinas	831 424-0011 Various
SAS German Auto	Pleasanton	925 846-4886 10% Parts
Schulba BMW Service	Belmont	650 592-7352 10% Parts orders
Sound Innovations	Hayward	510 471-9062 10% Parts
Track Star Racing	Mountain View	650 961-2350 10% Parts/Labor
Valley Motorwerks	Rancho Cordova	916 636-9526 10% Parts/Labor
Vanguard Motors	San Francisco	415 255-8450 10% Labor
West Bay Bavarian	San Rafael	415 457-0820 10% Parts/Labor/Dinan work
Dealership Discounts		
BMW of Fremont	Fremont	510 360-5900 10% Parts & Labor
BMW of Humboldt Bay	McKinleyville	707 839-4269 10% Parts
BMW of Monterey	Seaside	831 899-5555 10% Parts
BMW of Mountain View	Mountain View	650 943-1000 10% Parts
BMW of San Francisco	San Francisco	415 863-9000 10% Parts
East Bay BMW	Pleasanton	800 505-4801 10% Parts
Peter Pan BMW Parts/Svc	1625 Adrian Rd. Burlingame	650 204-7600 10% Parts
Roseville BMW	Roseville	916 782-9434 10% Parts
Sonnen BMW	San Rafael	415 482-2000 10% Parts
Stevens Creek BMW	Santa Clara	408 249-9070 10% Parts & Labor
Weatherford BMW	Berkeley	510 654-8280 Various

FACTORY AUTHORIZED BMW DEALERS



BMW CONCORD
1945 Market Street
Concord, CA 94520
925 682-3577

BMW OF FREMONT
5720 Cushing Parkway
Fremont, CA 94538
510 360-5900

BMW OF HUMBOLDT BAY
1795 Central Ave.
McKinleyville, CA 95519
707 839-4BMW (4269)

BMW OF MONTEREY
One Geary Plaza
Seaside, CA 93955
831 899-5555

BMW OF MOUNTAIN VIEW
150 E. El Camino Real
Mountain View, CA 94040
650 943-1000

BMW OF SAN FRANCISCO
1675 Howard St
San Francisco, CA 94103
415 863-9000

BMW OF SANTA MARIA
2150 South College Drive
Santa Maria, CA 93455
805 614-0306

COAST BMW
1484 Auto Park Way
San Luis Obispo, CA 93405
805 543-4423

EAST BAY BMW
4350 Rosewood Drive
Pleasanton, CA 94566
800 505-4801

PETER PAN BMW
2695 S. El Camino Real
San Mateo, CA 94403
650 349-9077

PRESTIGE BMW
2800 Corby Avenue
Santa Rosa, CA 95407
707 545-6602

SONNEN BMW
1599 E. Francisco Blvd
San Rafael, CA 94901
415 482-2000

STEVENS CREEK BMW
3737 Stevens Creek
Santa Clara, CA 95050
408 249-9070

WEATHERFORD MOTORS
735 Ashby Avenue
Berkeley, CA 94710
510 654-8280



CHAPTER INFORMATION

Board Members

GGC BOARD Board@ggcbmwcca.org
PRESIDENT Donna Seeley President@ggcbmwcca.org
VICE PRESIDENT Kelly Collins VicePresident@ggcbmwcca.org
SECRETARY Aleksey Kadukin Secretary@ggcbmwcca.org
TREASURER Tamara Hull Treasurer@ggcbmwcca.org
MEMBERSHIP CHAIR Ian Dunn 253 797-0273 MembershipChair@ggcbmwcca.org
MEMBERS-AT-LARGE Roger Ball, Canyon Chan
Event Staff
CHIEF DRIVING INSTRUCTORS Billy Maher 707 546-5572 Peter Vinsel TrackSchools@ggcbmwcca.org
CHIEF STEWARD Peter Guagenti ChiefSteward@ggcbmwcca.org
TRACK SCHOOL PROJECT MANAGER Kelly Collins TrackSchools@ggcbmwcca.org
DRIVING EVENTS COORDINATOR Tammi Hull DEC@ggcbmwcca.org
CHIEF SCRUTINEER Ramon Le Francois 408 956-1662
CAR-CONTROL CLINIC COORDINATORS Canyon Chan, Grant Low, Mark Magee, and Paula Williamson CarControl@ggcbmwcca.org
AUTOCROSS COORDINATOR Rodger Ball and Jeff Roberts Autox@ggcbmwcca.org
AUTOCROSS CAR CLASSIFICATIONS Daniel McCormick AutoxClassify@ggcbmwcca.org
TECHNICAL SESSION COORDINATOR Aleksey Kadukin TechSessions@ggcbmwcca.org
CLUB RACING OPEN ClubRacing@ggcbmwcca.org www.bmwccaclubracing.com
BMW FESTORICS COORDINATORS Linda Axelson and Jeff Cowan Info@festorics.org
SOCIAL EVENTS DIRECTOR Mike Zampiceni SocialDirector@ggcbmwcca.org
CHARITABLE EVENTS COORDINATOR Joe Fant CharitableEvents@ggcbmwcca.org

Bombe Team

EDITOR-IN-CHIEF Kelly Kirkland 650 400-9300 Bombe@ggcbmwcca.org
ADVERTISING MANAGER Percy Chow 925 323-4844 Cell 925 215-3547 Off Advertising@ggcbmwcca.org
AD BILLING MANAGER Percy Chow AdBills@ggcbmwcca.org
REGULAR CONTRIBUTORS Jonathan Bush, Percy Chow, Frank Cowan, and Dennis Harrold
PRINTING Commerce Printing
Requests for replacement or extra copies of the GGC newsletter should be directed to the membership chair.
Communications Team
COMMUNICATIONS MANAGER Kelly Collins CommMgr@ggcbmwcca.org
WEBMASTER Kris Linquist Webmaster@ggcbmwcca.org
GRAPHIC DESIGN Percy Chow www.percydesign.com
Area Representatives
NORTH BAY Paula Williamson 707 695-3998 NorthBayRep@ggcbmwcca.org
SAN FRANCISCO Ian Dunn 253 797-0273 SFAreaRep@ggcbmwcca.org
EAST BAY Mary Sandkohl 510 530-4871 EastAreaRep@ggcbmwcca.org
PENINSULA Ken Glidewell 650 799-8212 PeninsulaAreaRep@ggcbmwcca.org
SOUTH BAY Kris Linquist 408 392-0890 SouthAreaRep@ggcbmwcca.org
MONTEREY BAY AREA Mark Radovan MontereyAreaRep@ggcbmwcca.org
SAN LUIS OBISPO AREA Dennis Harrold 805 266-9214 SLOAreaRep@ggcbmwcca.org
BMW CCA Pacific Region VP
NATIONAL BOARD REPRESENTATIVE Jeff Cowan 650 322-4938 PacificRVP@bmwcca.org

GGC, BMW CCA

Golden Gate Chapter, BMW CCA, Inc. is a nonprofit California corporation, it is a chapter of the BMW Car Club of America, and is not connected with Bayerische Motoren Werke AG or BMW of North America. *Die Flüsternde Bombe* is a publication of the Golden Gate Chapter; all ideas, opinions, and suggestions expressed in regard to technical or other matters are solely those of the authors, and no authentication, endorsement, or guarantee is expressed or implied. Golden Gate Chapter BMW CCA, Inc. assumes no liability for any of the information contained herein. No factory approval is implied unless so indicated. Modification of your BMW within the warranty period may void the warranty, and some modifications may violate federal or state laws or regulations. All contents remain the property of the chapter, but BMW CCA and BMW ACA chapters may quote or copy from the publication, provided full credit is given to the author and the Golden Gate Chapter; unless otherwise noted or specifically prohibited.

Chapter Mailing Address:
Golden Gate Chapter BMW CCA
68 Mitchell Blvd, Suite 250
San Rafael, CA 94903

BMW CCA

The BMW Car Club of America, Inc. is a not-for-profit national association of over 70,000 members, dedicated to the enjoyment of driving BMWs. Membership is not limited to BMW owners and aims to provide access to driving and social events, maintenance and technical information, parts discounts, and more. Dues are \$48 per year, with an associate member added for \$10 more. Members receive the monthly *Roundel* magazine and a newsletter from their local chapter, or from a chapter of their choice. The Golden Gate Chapter is one of the largest chapters in the BMW CCA with over 4,300 members.

For a new membership or to renew an existing one, please call toll free 800 878-9292 or visit www.bmwcca.org. Visa and Mastercard accepted.

BMW CCA mailing address:
640 South Main St., Suite 201
Greenville, SC 29601
Phone: 864 250-0022
Fax: 864 250-0038
www.bmwcca.org

PRIVACY STATEMENT

By joining the BMW Car Club of America (BMW CCA), you provided personal information that allows us to contact you. BMW CCA provides this information to the Golden Gate Chapter of the BMW Car Club of America (GGC BMW CCA) for the following purposes:

- To send the GGC magazine (*Die Flüsternde Bombe*) by U.S. Mail.
- To help us create content and events most relevant to you.
- To alert you to updated information and other new services from ggcbmwcca.org using an email announcement list.

GGC BMW CCA does not distribute personal information to any third parties. The information you provide to BMW CCA to be used by the GGC will not be used for any other purpose—we promise.

MEMBER UPDATES

Membership address corrections are only accepted at the BMW CCA website or national office.

Mini WRC: Continued from page 15

Mini powered by BMW Motorsport

The heart of the Mini John Cooper Works WRC is the 1.6-liter, four-cylinder turbo engine with direct injection, which is also available in the Mini production models. The production engine was further developed by BMW Motorsport for the use in various categories according to FIA Super2000 regulations. The power transmission takes place via an Xtrac six-speed sequential gearbox. For its outings on the rally stages, the Mini Countryman chassis has been fitted with a roll cage developed by Prodrive, which exceeds the strict safety requirements of the International Automobile Federation (FIA).



Mini returns to its roots

Ian Robertson, Member of the Board of Management, Sales and Marketing BMW Group, speaks about what this move means for the brand: "Our involvement in the World Rally Championship effectively sees Mini returning to its roots. In the early years, success in the world of motorsport contributed significantly to the rapid rise of the Mini. Back then, people saw that this little car not only looked good in everyday traffic, but also had a sporty side. This has not changed since then. We chose the World Rally Championship for our stage in order to prove the sportiness of Mini cars to today's generation of drivers. The commitment also reinforces the key values of the Mini brand, excitement, and energy as well as underlining the manly side of the brand."

GGC



DIY Tire Rack: Continued from page 27

Step 5: Test and enjoy!

Before you load the rack with tires, I'd suggest a quick safety test. I tested my racks by having a friend (of similar weight) and me sit on the assemblies. Hardly high tech, but if it will support 340 pounds of people, 200 pounds of mounted tires will hardly stress it. Listen for BAD NOISES as you test the assembly and be prepared to move quickly if the noises become REALLY BAD. After testing, load the tires into the rack and enjoy your newfound floor space!

I have not applied any type of finish to the wood; I figure that paint or varnish will be chipped off by unloading and loading tires, and I have concerns about reactions between wood finishes and the tires. The tires are usually dry when I'm loading them, and the few times wet tires have been placed in the original rack haven't seemed to have done any

harm. Other than checking that the turnbuckles are snug and the rack remains level every once in a while, maintenance is limited to vacuuming off the sand and gravel that falls onto the rack from the tires.

For those interested, the anti-theft device shown in Photo 1 and Photo 2 is constructed from a 40" length of 1/2" Schedule 40 PVC pipe, an 8' length of 3/8" chain, and a big padlock. The pipe allows the chain to be inserted through the wheel spokes without damaging the finish. It may not stop someone with a 3' set of bolt cutters, but it sure will slow them down.

GGC



yelp **5 STAR RATING**
 www.edgemotorworks.com

The New West Dublin/Pleasanton BART Station is Open! Now Announcing Service to EDGE Motorworks



EDGE Motorworks is adjacent to the Dublin side of the station – near Chase Bank, in the Golden Gate Business Park.

Service for Your BMW or MINI is Now Only a Few Steps Away from BART.

With the opening of the West Dublin/Pleasanton BART station – you can drop off your car in the morning, work a full day at the office, and then pick it up for your drive home.

And since EDGE Motorworks offers comprehensive service and repair, (like an oil change or Inspection I/II) most of your work can be done in a day. So for your next service visit, let EDGE Motorworks take care of your car while you watch others sit in traffic.

EDGE Motorworks
 BMW & MINI Specialists

(925) 479-0797

6443 Golden Gate Drive
 Dublin, CA 94568

Please mention you saw this ad

BMW CCA Members Always Receive **10% Off Labor**

Dear Mr. Valentine:

Every fighter pilot knows – cover your six. After one day with my new Valentine One, I see why everybody at the base keeps talking about their Vee-Ones.

I picked up a beep on the Interstate, slow at first but quickening, just like I was coming up on something. But the Radar Locator pointed behind – something was coming up on me!

He was hard to spot, a slick-top sneaking up through traffic. He went on by and got small. Then I saw blue flashes in the distance.

When I caught up he had a Mustang, its ordinary detector still winking red in the windshield. Of course, ordinary detectors don't look behind. Vee-One is like driving with a buddy for back-up.

Yours truly,

Slam
 L.C. "Slam" Lewis
 Tucson, AZ

Dear Mr. Valentine:

Hey, I think I owe you one.

My commute goes past two miles of malls, which my old detector said was one long X-band false. Nope. Now I see it's two miles of little alerts that blur together. The Radar Locator tracks each one as I drive by – pointing Ahead first, then Beside and finally Behind.

Yesterday, it pointed out the usual places. And one more. Hmmmmm. The Ahead arrow flashed insistently. Guess what? Radar shooting commuters from the shoe-store parking lot.

My old unit would have beeped, same as always. But yours saw the trap. That could be an ad, right? Valentine One is the one to have when there's more than one alert.

Go ahead, use it, because I definitely owe you.

Sincerely amazed,

Sal Molinari
 Sal Molinari
 Hartford, CT

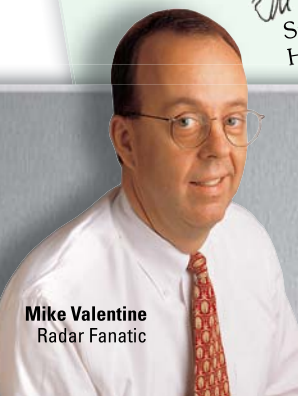

Mike Valentine
 Radar Fanatic

Trust...V1 earns it one ambush at a time

Radar Locator
 Tracks one or more radars at the same time; points to each.

Bogey Counter

Tells how many:
 Radar hiding within a false alarm? Two radars working the same road? Reads instantly.

Control Knob

Turns On/Off, adjust volume, press to mute.

Muted-Volume Lever

Sets volume you hear after muting.

Radar Antenna

Scans behind for radar.



Ahead



Beside



Behind



Radar Strength

More LEDs glow as radar strengthens.

Memo To: Mike Valentine

Kansas, 54 west to Liberal, so flat I can see next week. No traffic, really, except for the Durango I've been closing on through four or five iPod tunes (George Jones was made for Kansas).

Off the shoulder ahead, maybe a half mile, what, a furniture van? Tailgate up, brown-shirted guy inside; looks like he's rearranging the load. V1 lets loose an EEEEEEEEE sound. Laser! I hammer the brakes. EEEEEEEEE.

Can't be laser. There's nothing around. Just me and the Durango, now passing the van. Wait...inside with the furniture, dang, another brown shirt, crouched behind a sofa, steadying his laser gun over the backrest. Double dang! The first shirt is talking into a cop radio as I go by.

And now I see what the deal is; three cruisers backed up in a tight line against the nose of the van. The lead car is rolling, in pursuit of the Dodge I was fixing to pass. The others stay. Whew! V1 must have caught a laser glint as it ricocheted off the SUV.

C. Phillips
 Clay Phillips
 Tulsa, OK

Dear Mr. Valentine:

Just east of Texarkana on I-30, my Valentine One picked up X-band. The Radar Locator pointed "Ahead." Over the rise, sure enough, flashing lights. Smokey had a semi on the shoulder.

As I eased past, I watched the Radar Locator; it's kinda fun seeing it tracking radar from "Ahead" to "Beside" to "Behind" as you go by. It stayed "Ahead." What the #@?! Man, I saw Smokey. And I put him behind ahead. Could it be?

Yep. Over the next hill, another Smokey, harvesting the ignorant. Without the Radar Locator, I would have been one of them. Valentine One is like having my own AWACS.

Thanks, Big Guy

Ted Reynolds
 Ted Reynolds
 Dallas, TX

www.valentine1.com



Valentine Research, Inc. Ph 513-984-8900
 Department No. XV41 Fx 513-984-8976
 10280 Alliance Road
 Cincinnati, Ohio 45242



Call toll-free 1-800-331-3030

Valentine One Radar Locator with Laser Detection - \$399

Carrying Case - \$29 Concealed Display - \$39

Plus Shipping / Ohio residents add sales tax

30-Day Money-Back Guarantee

Valentine One is a registered trademark of Valentine Research, Inc.

© 2011 VRI

Want to join the Club? Call 800 878-9292 or go to www.bmwcca.org and sign up for only \$48!

**BMW Car Club
of America
Golden Gate Chapter**



Golden Gate Chapter, BMW CCA
68 Mitchell Blvd, Suite 250
San Rafael, CA 94903
www.ggcbmwcca.org

Presort Standard
US Postage
PAID
Sacramento, CA
Permit 185

POSTMASTER PLEASE NOTE:
Material is dated, thanks.

HAVE YOU MOVED? Please send address changes directly to the BMW CCA National Office at: info@bmwcca.org, or sign in to your account and update your membership record at www.bmwcca.org.

live green print green

At Commerce Printing, we are committed to minimizing the environmental impact of our operations. From simply recycling our paper trimmings to powering our entire facility with wind energy, we remain dedicated to the conservation of our natural resources for the present as well as future generations.

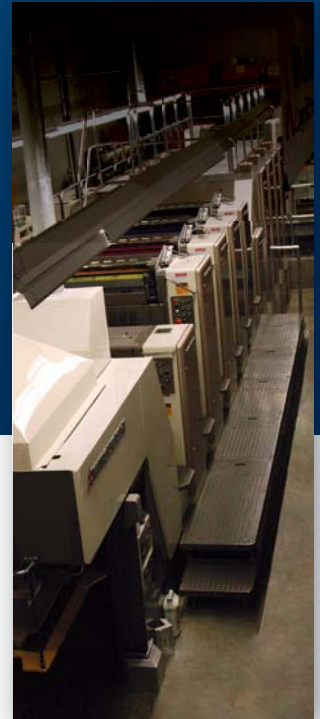

Commerce Printing
SERVICES



916.442.8100 • www.commerceprinting.com

